

## Product description

### Inkocross couplings KWK

The INKOMA-Inkocross coupling - KWK, is a machine component which uniformly transmits torque between input and output. The INKOMA-Inkocross coupling can tolerate a parallel offset and an angular deflection of the shafts. In addition it may be loaded axially in both tension and compression.

INKOMA - GROUP  
Couplings

by

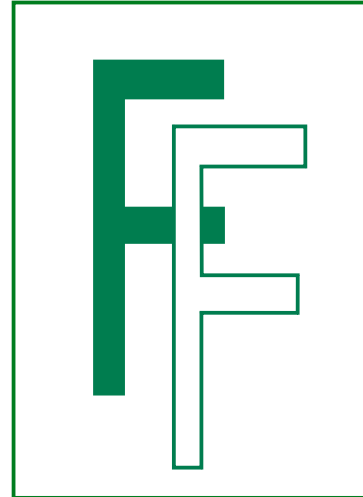



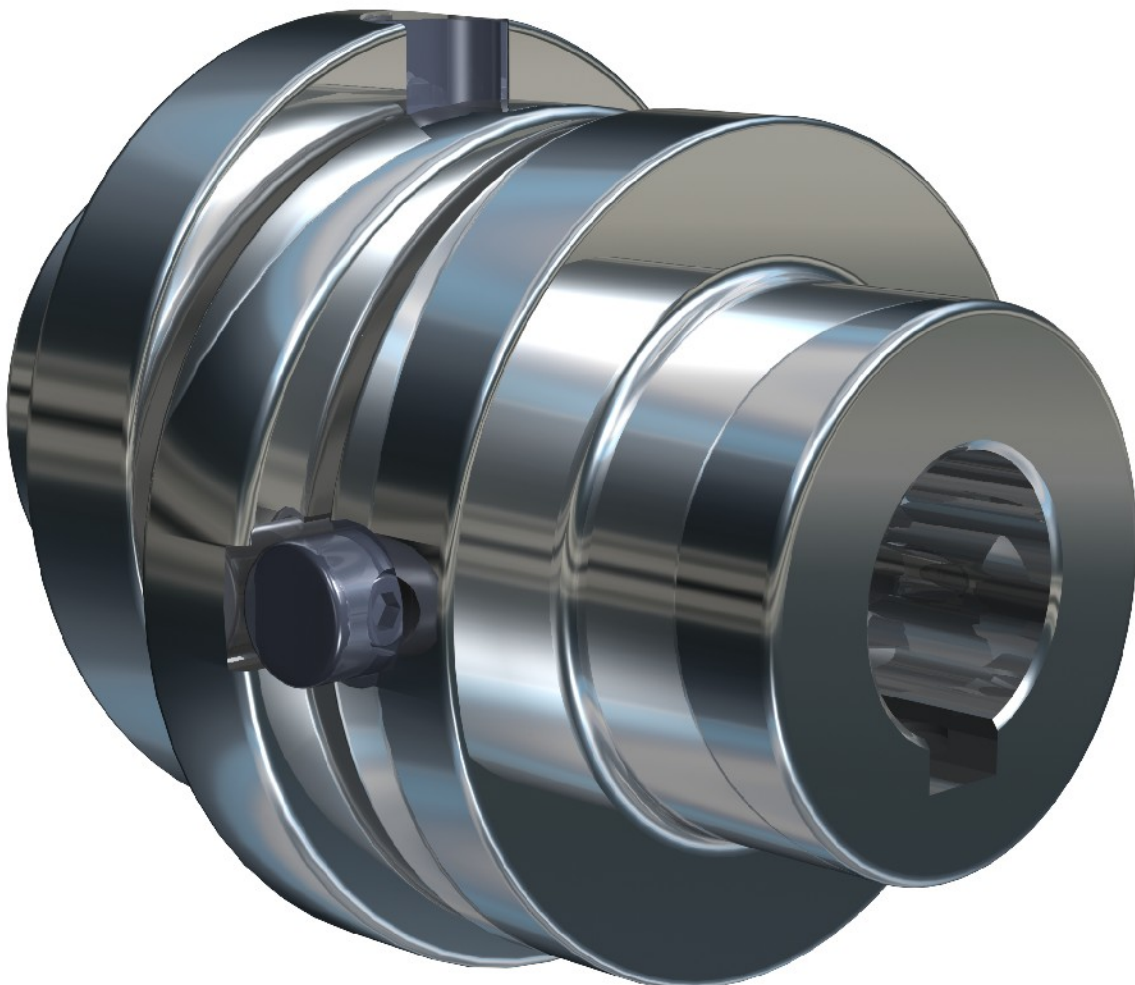





FRANCIS AND FRANCIS Ltd.  
[www.powertransmissions.co.uk](http://www.powertransmissions.co.uk)

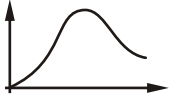
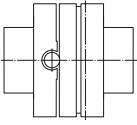

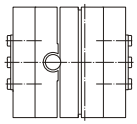
## Contents list

### Inkocross-couplings KWK

		<b>Technical information</b> versions A1, A2, A3, A7	page <b>003</b>
		<b>Technical information</b> coupling selection and specification configuration and function assembly	page <b>004 - 005</b>
		<b>Dimensions</b> versions A1, A2	page <b>006 - 007</b>
		<b>Dimensions</b> versions A3, A7	page <b>008 - 009</b>
		<b>Dimensions for ISP-E - Inkofix tension flange</b> for version A3	page <b>010 - 011</b>

## Technical information

### Inkocross-couplings KWK

The INKOMA-Inkocross coupling KWK is available in the following versions:

**A1 = Flange version:**

Both outer discs have fixing holes for socket head cap screws for connecting components. On pitch circle "C" there are four fixing holes.

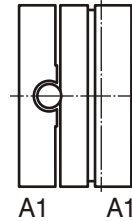

**A2 = Hub version:**

Both outer discs have finished bores in outward facing hubs and keyways to BS 4235 (DIN 6885/1).

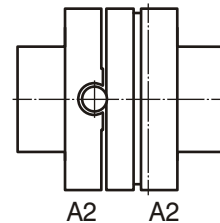

**A3 = Tension hub version:**

Flange version A1 with additional shrink disc. The shrink disc allows keyless fitting to the shaft. For details of the tension flange see page 10.

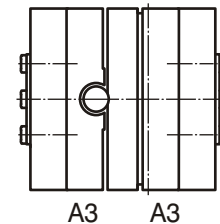

**A7 = Split hub version:**

This hub version has two components - a fixed and a removable part allowing radial clamping to the shaft, it also has a keyway to BS 4235 (DIN 6885/1). This version requires no axial displacement of the shaft for assembly and disassembly.

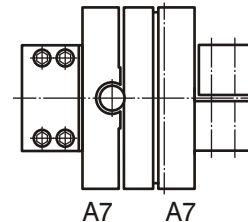

**Combinations:**

Each coupling can combine any of these versions. E.g. A1/A2 - one side with flanged version with fixing holes for socket head cap screws and the other side with outward facing bored hub with keyway to BS 4235 (DIN 6885).

All versions may be combined with one another.

**Special versions:**

In addition to basic versions, customer specific executions are also possible e.g. incorporating sprocket, gears, shaft, etc. in the outer discs.

## Technical information

### Inkocross-couplings KWK

#### Coupling selection and specification:

The permitted max. torque of the coupling should always be greater than the nominal torque of the loaded components.

#### Drive torque:

$$T_A \text{ [Nm]} = \frac{P_A \text{ [kW]} \cdot 9550}{n_A \text{ [1/min]}}$$

#### Load torque:

$$T_L \text{ [Nm]} = \frac{P_L \text{ [kW]} \cdot 9550}{n_L \text{ [1/min]}} \cdot K$$

In calculating the operating torque the appropriate factors should be incorporated:

Type of load	Load factor K
no shock	1,0
moderate shock	1,8
heavy shock	2,5
heavy reversing shock	3,0

#### Calculation example and coupling selection:

The drive is from a diesel engine with moderate shock.

The input power is 3 kW at 280 1/min.

$$T_A = 9550 \cdot \frac{3}{280} = \underline{\underline{102,3 \text{ Nm}}}$$

$$T_L = 9550 \cdot \frac{3}{280} \cdot 1,8 = \underline{\underline{184,2 \text{ Nm}}}$$

**Selected Coupling:** KWK 64.90

#### Explanation:

$T_A$ [Nm]	= drive torque
$T_L$ [Nm]	= load torque
$P_A$ [kW]	= input power at the coupling
$P_L$ [kW]	= load power at the coupling
$n_A$ [1/min]	= input speed
$n_L$ [1/min]	= load speed
K	= load factor

#### Configuration and function:

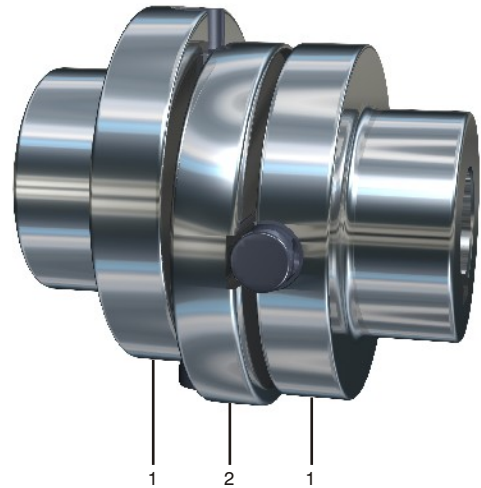

#### Configuration:

From a number of basic versions come various possibilities. The coupling consists of two outer discs with machined circular recesses fitted with frictionless bushes "1", and a centre disc "2" with 2 x 90° opposed sliding 'shafts', one on each face. Dependent on the degree of radial or angular offset or misalignment, small or large oscillating motion of this disc will occur through each revolution. This permits relatively large shaft rotational errors to be tolerated.

Special sizes and special versions can be supplied. Please speak to our technical personnel.

#### The INKOMA-Inkocross coupling KWK has the following important features:

- torsionally stiff connection with shaft offset and angular misalignment compensation
- synchronous function with radial offset, ie. no angular error per revolution (no phase displacement)
- very high torque transmission from an extremely compact unit
- simple assembly and dis-assembly
- good dry running characteristics due to careful material matching
- rust free versions available

## Technical information

### Inkocross-coupling KWK

#### Assembly:

To achieve problem-free function for the KWK Inkocross coupling the connected input and output shafts must be adequately supported in rolling bearings (see fig. 1). It is dangerous to install Inkocross couplings in tandem since the coupling could slip out of connection (fig. 2).

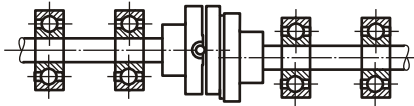

Fig. 1

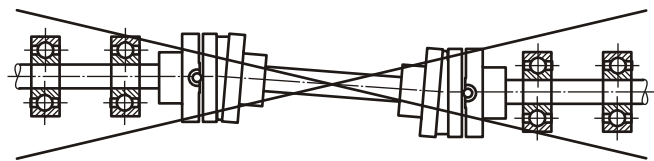

Fig. 2

When the Inkocross coupling is assembled to fixed but offset input and output shafts, the disc automatically adopts the position appropriate to the offset (radial or angular displacement). The inkocross coupling is equipped with maintenance free components. Hence the coupling frictionless bushes do not require re-lubrication under normal conditions of load and speed. Premature wear and possible failure of the coupling can result if the listed values for angular and radial displacement between the driving and driven shafts are exceeded. The coupling must be protected from the direct effects of dust, dirt, water, etc.

#### Temperature range:

Inkocross couplings with maintenance free frictionless bushes are suitable for a temperature range of -10°C to +100°C.

## Dimensions KWK A1, A2

### Inkocross-coupling KWK

The INKOMA-Inkocross-coupling KWK is normally available in the following version:

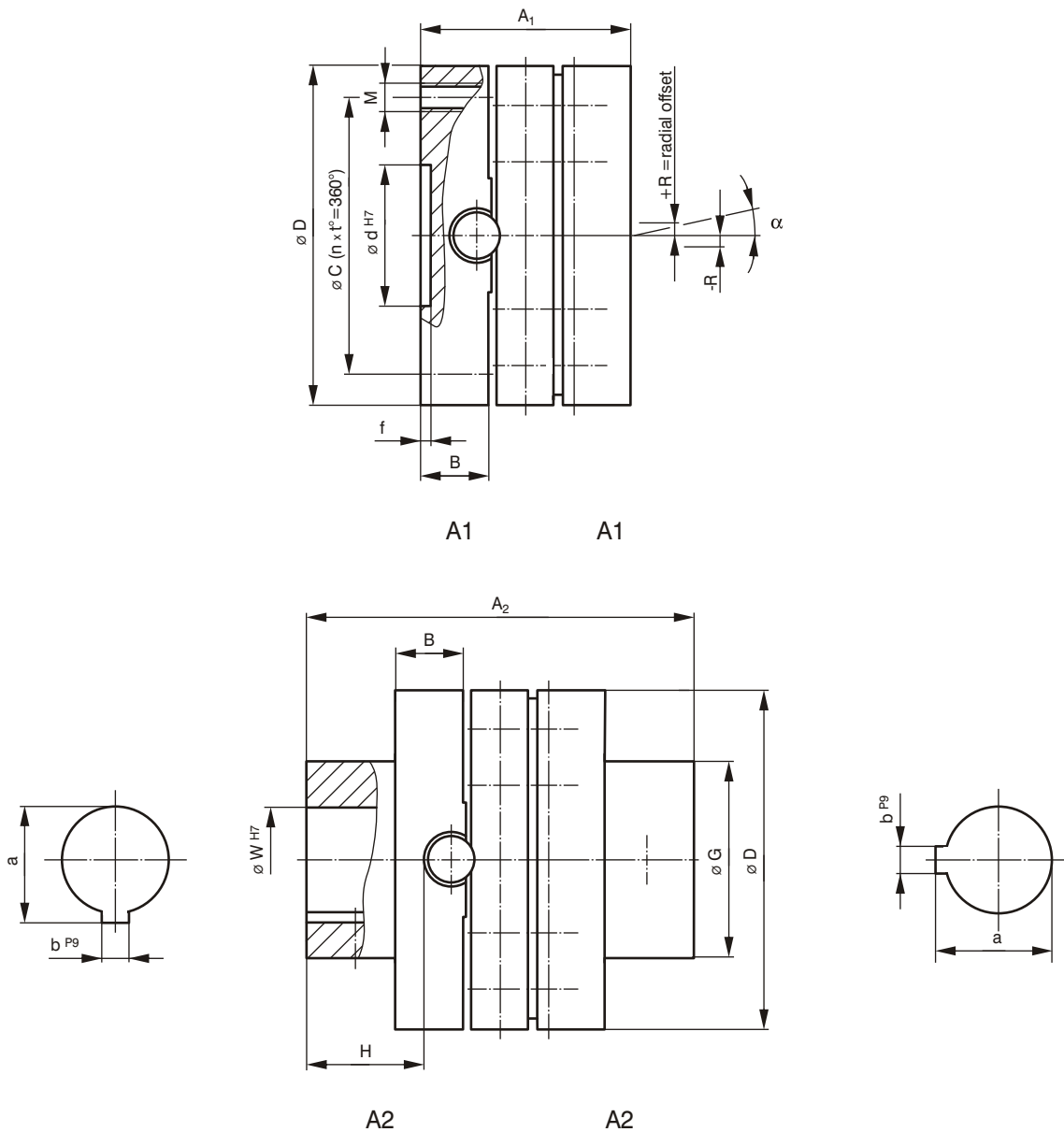

### Ordering example:

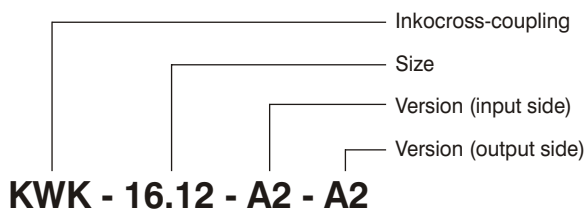

# Inkocross couplings

Order code	Dimensions [mm]												Mounting holes		
	A <sub>1</sub>	A <sub>2</sub>	B	C	D	G	H	W <sup>1)</sup>	a	b	d	f	Thread M	Number n	Hole pitch t [°]
KWK-16.12	-	16	6,2	-	12	-	4	4 <sup>2)</sup>	-	-	-	-	-	-	-
KWK-20.18	-	20	7,8	-	18	-	5	5 <sup>2)</sup>	-	-	-	-	-	-	-
KWK-26.25	26	35	10	18	25	-	10	6 <sup>2)</sup>	-	-	12	3	M4	2	180
KWK-35.40	35	54	12,5	30	40	-	15	12	13,8	4	18	3	M5	2	180
KWK-44.50	44	72	14,5	35	50	32	20	14	16,3	5	22	3	M6	4	90
KWK-64.70	64	85	22	48	70	35	20	16	18,3	5	25	5	M10	4	90
KWK-64.90	64	119	22	70	90	55	37	25	28,3	8	45	5	M10	4	90
KWK-64.120	64	129	21	98	120	60	42	30	33,3	8	50	5	M10	4	90
KWK-64.150	64	129	21	128	150	70	42	35	38,3	10	60	5	M12	4	90
KWK-80.100	80	131	28	70	100	54	37	30	33,3	8	40	5	M12	4	90
KWK-80.120	80	141	27	90	120	65	42	30	33,3	8	50	5	M12	4	90
KWK-80.140	80	161	27	110	140	70	52	35	38,3	10	50	5	M12	4	90
KWK-80.160	80	161	26	130	160	70	52	40	43,3	12	60	5	M12	4	90
KWK-95.140	95	172	32,5	100	140	70	52	35	38,3	10	55	5	M16	4	90
KWK-95.160	95	172	32,5	120	160	85	52	40	43,3	12	60	5	M16	4	90
KWK-110.160	110	184	38	115	160	75	52	40	43,3	12	60	5	M16	4	90
KWK-110.180	110	204	38	135	180	90	62	45	48,8	14	70	5	M16	4	90
KWK-110.200	110	224	38	152	200	100	72	50	53,8	14	80	5	M16	4	90
KWK-120.200	120	230	40	150	200	100	70	50	53,8	14	80	7	M20	4	90
KWK-120.250	120	250	40	200	250	120	80	60	64,4	18	100	7	M20	4	90
KWK-120.310	120	280	40	260	310	160	95	80	85,4	22	150	7	M20	6	60

<sup>1)</sup> preferred bores, also available in other sizes

<sup>2)</sup> without keyway, with clamping screw

Order code	Operational data				Mass <sup>3)</sup>	CAD-No.	CAD-No.				
	Radial offset <sup>4)</sup>	Angular misalignment	Static torque	Inertia <sup>3)</sup>							
	±R [mm]	α [°]	T <sub>stat</sub> [Nm]	J [kg cm <sup>2</sup> ]	[kg]	[A1-A1]	[A2-A2]				
KWK-16.12	1	3	6	0,00072	0,004	-	48 003				
KWK-20.18	2	3	15	0,0052	0,013	-	48 053				
KWK-26.25	3	3	19	0,0156	0,02	48 101	48 103				
KWK-35.40	3	3	71	0,580	0,29	48 151	48 153				
KWK-44.50	3	3	78	1,594	0,51	48 201	48 203				
KWK-64.70	3,5	3	104	8,024	1,31	48 301	48 303				
KWK-64.90	3,5	3	586	26,629	2,63	48 321	48 323				
KWK-64.120	4	3	910	82,980	4,61	48 341	48 343				
KWK-64.150	4	3	1183	205,59	7,31	48 361	48 363				
KWK-80.100	5	3	624	54,375	4,35	48 401	48 403				
KWK-80.120	5	3	910	110,34	6,13	48 421	48 423				
KWK-80.140	5	3	1183	205,80	8,40	48 441	48 443				
KWK-80.160	6	3	1560	338,24	10,57	48 461	48 463				
KWK-95.140	5	3	1183	244,51	9,98	48 501	48 503				
KWK-95.160	6	3	1560	52,08	13,02	48 521	48 523				
KWK-110.160	6	3	1560	480,00	15,00	48 601	48 603				
KWK-110.180	7	3	2730	765,86	18,91	48 621	48 623				
KWK-110.200	8	3	2730	1163,00	23,26	48 641	48 643				
KWK-120.200	8	3	2730	1224,00	24,48	48 701	48 703				
KWK-120.250	10	3	6630	2951,60	37,78	48 721	48 723				
KWK-120.310	15	3	13000	6944,43	57,81	48 741	48 743				

<sup>3)</sup> for version A1 - A1

<sup>4)</sup> depends on the speed, valid for up to 500 1/min

## Dimensions KWK A3, A7

### Inkocross-coupling KWK

The INKOMA-Inkocross-coupling KWK is normally available in the following version:

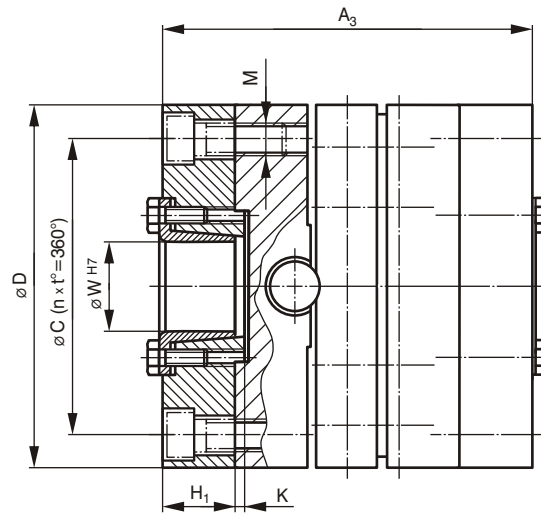

A3                      A3  
 $A3 = A1 + \text{ISP-E}$   
 For further details see page 10.

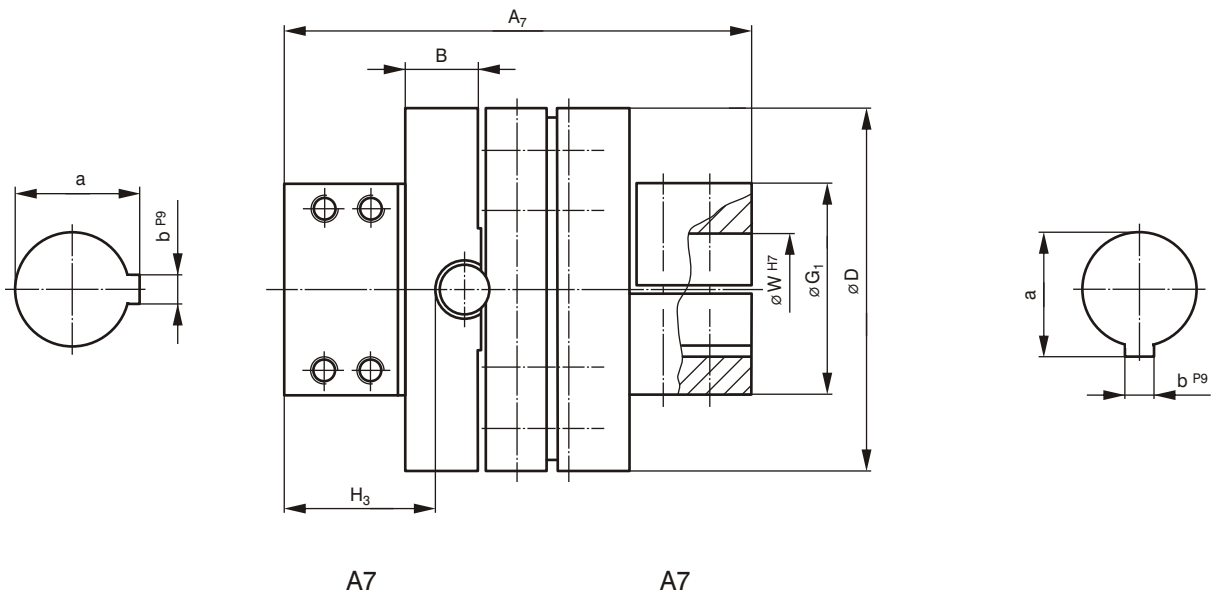

### Ordering example:

\_\_\_\_\_ Inkocross-coupling  
 \_\_\_\_\_ Size  
 \_\_\_\_\_ Version (input side)  
 \_\_\_\_\_ Version (output side)  
**KWK - 64.90 - A3 - A3**

# Inkocross couplings

Order code	Dimensions [mm]												Mounting holes		
	A <sub>3</sub>	A <sub>7</sub>	B	C	D	H <sub>1</sub>	H <sub>3</sub>	K	W <sup>1)</sup>	a	b	G <sub>1</sub>	Thread M	Number n	Hole pitch t [°]
KWK-16.12	4)	3)	-	-	-	-	-	-	-	-	-	-	-	-	-
KWK-20.18	4)	3)	-	-	-	-	-	-	-	-	-	-	-	-	-
KWK-26.25	4)	35	-	-	25	-	10,5	-	6 <sup>2)</sup>	-	-	-	-	-	-
KWK-35.40	4)	54	-	-	40	-	15	-	12	13,8	4	-	-	-	-
KWK-44.50	4)	76	14,5	-	50	-	22	-	14	16,3	5	40	-	-	-
KWK-64.70	4)	114	23	-	70	-	34,5	-	16	18,3	5	40	-	-	-
KWK-64.90	92	124	22	70	90	14	39,5	3	25	28,3	8	50	M10	4	90
KWK-64.120	112	134	21	98	120	24	44,5	3	30	33,3	8	65	M10	4	90
KWK-64.150	112	163	21	128	150	24	59	3	35	38,3	10	75	M12	4	90
KWK-80.100	4)	150	28	-	100	-	46,5	-	30	33,3	8	65	-	-	-
KWK-80.120	130	150	27	90	120	25	46,5	3	30	33,3	8	65	M12	4	90
KWK-80.140	140	179	27	110	140	30	61	3	35	38,3	10	75	M12	4	90
KWK-80.160	140	189	26	130	160	30	66	3	40	43,3	12	90	M12	4	90
KWK-95.140	165	194	32,5	100	140	35	63	3	35	38,3	10	80	M16	4	90
KWK-95.160	165	204	32,5	120	160	35	68	3	40	43,3	12	90	M16	4	90
KWK-110.160	200	219	38	115	160	45	69,5	3	40	43,3	12	90	M16	4	90
KWK-110.180	200	230	38	135	180	45	75	3	45	48,3	14	100	M16	4	90
KWK-110.200	220	230	38	152	200	55	75	3	50	53,8	14	100	M16	4	90
KWK-120.200	250	270	40	150	200	65	90	5	50	53,8	14	115	M20	4	90
KWK-120.250	260	290	40	200	250	70	100	5	60	64,4	18	150	M20	4	90
KWK-120.310	5)	300	40	260	310	5)	105	5	80	85,4	22	170	M20	6	60

<sup>1)</sup> preferred bores, also available in other sizes

<sup>4)</sup> A3 version not available

<sup>2)</sup> without keyway, with clamping screw

<sup>5)</sup> to customer requirement

<sup>3)</sup> A7 version not available

Order code	Operational data				Mass <sup>7)</sup> [kg]	CAD-No. [A7-A7]						
	Radial offset <sup>6)</sup> ±R [mm]	Angular misalignment α [°]	Static torque T <sub>stat</sub> [Nm]	Inertia <sup>7)</sup> J [kg cm <sup>2</sup> ]								
KWK-16.12	-	-	-	-	-	-						
KWK-20.18	-	-	-	-	-	-						
KWK-26.25	3	3	19	0,0156	0,02	48 106						
KWK-35.40	3	3	71	0,580	0,29	48 156						
KWK-44.50	3	3	78	1,594	0,51	48 206						
KWK-64.70	3,5	3	104	8,024	1,31	48 306						
KWK-64.90	3,5	3	586	26,629	2,63	48 326						
KWK-64.120	4	3	910	82,980	4,61	48 346						
KWK-64.150	4	3	1183	205,59	7,31	48 366						
KWK-80.100	5	3	624	54,375	4,35	48 406						
KWK-80.120	5	3	910	110,34	6,13	48 426						
KWK-80.140	5	3	1183	205,80	8,40	48 446						
KWK-80.160	6	3	1560	338,24	10,57	48 466						
KWK-95.140	5	3	1183	244,51	9,98	48 506						
KWK-95.160	6	3	1560	52,08	13,02	48 526						
KWK-110.160	6	3	1560	480,00	15,00	48 606						
KWK-110.180	7	3	2730	765,86	18,91	48 626						
KWK-110.200	8	3	2730	1163,00	23,26	48 646						
KWK-120.200	8	3	2730	1224,00	24,48	48 706						
KWK-120.250	10	3	6630	2951,60	37,78	48 726						
KWK-120.310	15	3	13000	6944,43	57,81	48 746						

<sup>6)</sup> depends on the speed, valid for up to 500 1/min

<sup>7)</sup> for version A1 - A1

## Dimensions

### ISP-E - Inkofix tension flange

For version A3.

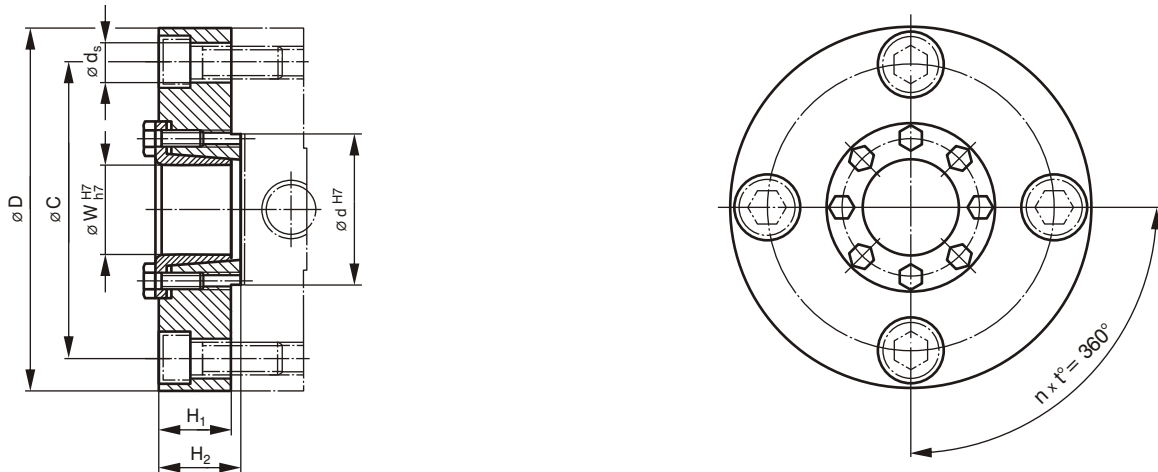

#### Explanation:

- $T_{stat}$  = maximum transmissible torque for tension flange
- $F_{ax}$  = maximum transmissible axial force for tension flange
- $T_A$  = required tightening torque of the tension screws

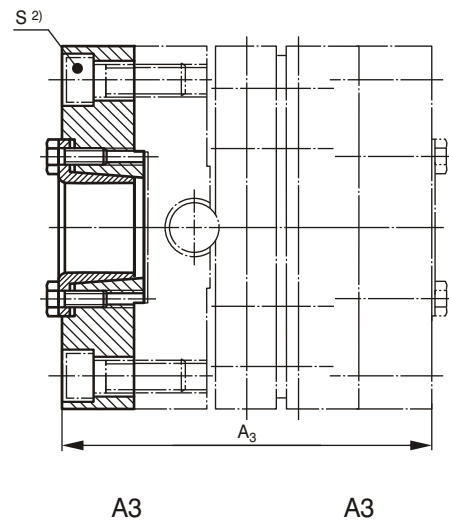

<sup>2)</sup> Mounting screws are not supplied.

#### Ordering example:

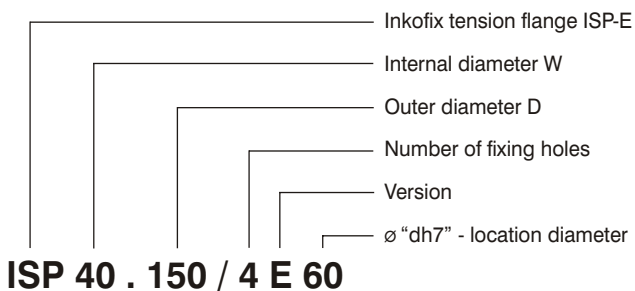

# Inkocross couplings

Order code Coupling	Order code Tension flange	Dimensions [mm]						Mounting holes								
		d	C	D	H <sub>1</sub>	H <sub>2</sub>	W	d <sub>s</sub>	n	t [°]						
KWK-64.90	ISP 25.90/4 E45	45	70	90	14	17	25	11	4	90						
KWK-64.120	ISP 30.120/4 E50	50	98	120	24	27	30	11	4	90						
KWK-64.150	ISP 35.150/4 E60	60	128	150	24	27	35	13	4	90						
KWK-80.120	ISP 30.115/4 E50	50	90	115	25	28	30	13	4	90						
KWK-80.140	ISP 35.135/4 E50	50	110	135	30	33	35	13	4	90						
KWK-80.160	ISP 40.155/4 E60	60	130	155	30	33	40	13	4	90						
KWK-95.140	ISP 35.130/4 E55	55	100	130	35	38	35	18	4	90						
KWK-95.160	ISP 40.150/4 E60	60	120	150	35	38	40	18	4	90						
KWK-110.160	ISP 40.145/4 E60	60	115	145	45	48	40	18	4	90						
KWK-110.180	ISP 45.165/4 E70	70	135	165	45	48	45	18	4	90						
KWK-110.200	ISP 50.185/4 E80	80	152	185	55	58	50	18	4	90						
KWK-120.200	ISP 50.190/4 E80	80	150	190	65	70	50	22	4	90						
KWK-120.250	ISP 60.240/4 E100	100	200	240	70	75	60	22	4	90						
KWK-120.310	1)	1)	1)	1)	1)	1)	1)	1)	1)	1)						

1) to customer requirement

Order code Coupling	Order code Tension flange	Tension screw		Operational data			Mounting screws 2)	Mass (tension flange) [kg]	CAD-No.	
		ISO 4017 (DIN 933) 10.9	Tightening torque T <sub>A</sub> [Nm]	Torque T <sub>stat.</sub> [Nm]	max. axial force F <sub>ax</sub> [kN]	Mass moment of inertia J [kg cm <sup>2</sup> ]				
KWK-64.90	ISP 25.90/4 E45	8xM6x16	12	595	48	6,5	4xM10x20	3)	0,6	53-1203
KWK-64.120	ISP 30.120/4 E50	8xM6x16	16,5	1224	82	36	4xM10x25		1,9	53-1204
KWK-64.150	ISP 35.150/4 E60	8xM6x16	16,5	1690	97	95	4xM12x25		3,2	53-905
KWK-80.120	ISP 30.115/4 E50	8xM6x16	16,5	1440	96	34	4xM12x30		1,9	53-906
KWK-80.140	ISP 35.135/4 E50	8xM6x16	16,5	1690	97	75	4xM12x35		3,1	53-907
KWK-80.160	ISP 40.155/4 E60	8xM6x16	12	1920	96	117	4xM12x35		3,9	53-1218
KWK-95.140	ISP 35.130/4 E55	8xM8x25	40	2980	170	77	4xM16x40		3,0	53-1208
KWK-95.160	ISP 40.150/4 E60	8xM8x25	40	3400	170	135	4xM16x40		4,5	53-909
KWK-110.160	ISP 40.145/4 E60	6xM10x30	79	5640	273	153	4xM16x50		4,8	53-1210
KWK-110.180	ISP 45.165/4 E70	8xM10x30	79	6320	281	256	4xM16x50		7,0	53-911
KWK-110.200	ISP 50.185/4 E80	8xM10x30	79	7180	287	496	4xM16x60		10,8	53-912
KWK-120.200	ISP 50.190/4 E80	8xM12x40	135	12400	496	656	4xM20x70		13,5	53-1216
KWK-120.250	ISP 60.240/4 E100	8xM12x40	135	15860	529	1798	4xM20x80		23,5	53-1217
KWK-120.310	1)	1)	1)	1)	1)	1)	1)		1)	

1) to customer requirement

2) Mountings screws are not supplied.

3) DIN 6912