

Product description

Inkoturn couplings IKT

The INKOMA Inkoturn coupling (IKT) is a flexible coupling with high torsional rigidity, which has been developed for applications requiring high speed and where shaft misalignment is present.

It can accept axial, radial and angular misalignment. Due to the design of the coupling negligible reaction forces are seen at the bearings due to misalignment. Developed with low mass, low inertia and being dynamically balanced the IKT coupling is suitable for dynamic applications where angular misalignment is present.

Under normal operating conditions the coupling is maintenance free and offers a long service life. However, the coupling should be protected against jet water, dust and dirt ingress. As it has a modular structure it can be installed complete or assembled in parts. The central disc (element) is manufactured with special material therefore it is electrically isolating and can absorb oscillation and impact loads. Torque can be transferred backlash free with maximum angular misalignment.

Typical applications are: rotary transducers, encoders, tachos, measuring systems, packaging machines, paper industry, printers, etc.

INKOMA - GROUP
Couplings

by

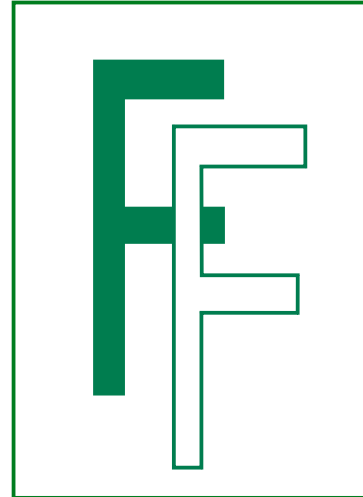



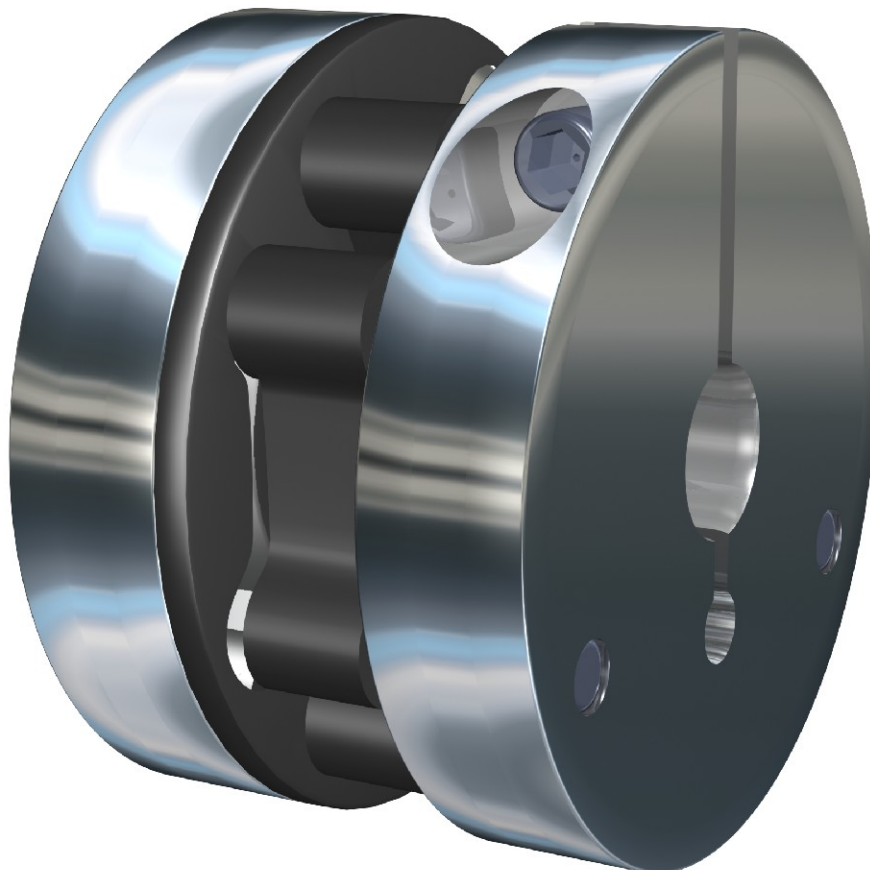



FRANCIS AND FRANCIS Ltd.
www.powertransmissions.co.uk

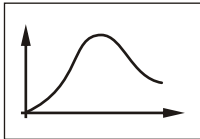
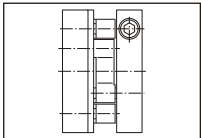

Contents list

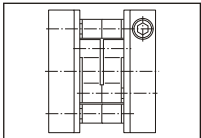
Inkoturn couplings IKT

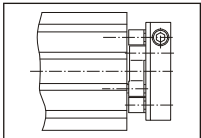
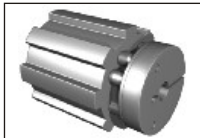
		Technical information Inkoturn test stand Structure and function	page 003
		Technical information Coupling selection and specification Assembly	page 004 - 005
		Dimensions for IKT single design Inkoturn couplings	page 006 - 007
		Dimensions for IKT double design Inkoturn couplings	page 008 - 009
		Examples Special models are possible	page 010

Technical information

Inkoturn couplings IKT

Inkoturn test stand:

All technical data for the coupling was obtained by our own test equipment developed in conjunction with technical universities.

The values calculated by the Finite Element Analysis (FEA) were confirmed by our own tests and by applications in the field.

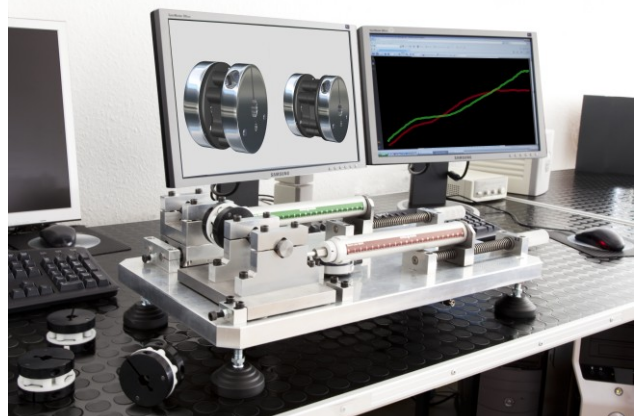

Coupling test stand

Structure and function:

The coupling consists of two anodized aluminium clamping hubs "1", available with different bore sizes, each fitted with a clamping screw to lock the hub into position. The clamping hubs are fitted with steel drive pins and are connected via a special plastic element "2".

The use of special material and geometry of the central disc result in minimal reaction forces being seen under misalignment conditions. Reaction forces are virtually zero with low misalignment.

The Inkoturn coupling is available in "single" and "double" disc design. The double disc design consists of two central discs and can transmit higher torque than the single disc version.

Special designs and sizes are available. Customised designs for applications requiring special materials, as required by the Food Industry for example can be achieved.

Contact our sales offices for further details.

Single design



Double design

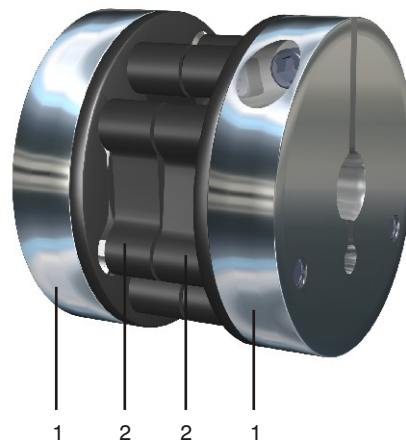

1 - Clamping hub
2 - Central disc

The INKOMA Inkoturn coupling (IKT) has the following characteristics:

- no angular velocity changes with shaft displacement
- robust and maintenance free
- can absorb impact and oscillation
- can accommodate large radial and axial misalignment plus angular misalignment
- modular construction
- central disc can be combined with different hubs
- economical/ cost effective
- low inertia
- electrically isolating
- simple installation with clamping hubs
- the special material and patented design of the central disc compensates for misalignment with extremely small reaction forces
- coupling parts can be installed separately
- large selection of bore diameters

Technical information

Inkoturn couplings IKT

Coupling selection and specification:

The permitted max. torque of the coupling T_{stat} [Nm] should always be greater than the nominal torque of the loaded components.

Drive torque:

$$T_A \text{ [Nm]} = \frac{P_A \text{ [kW]} \cdot 9550}{n_A \text{ [1/min]}}$$

Load torque:

$$T_L \text{ [Nm]} = \frac{P_L \text{ [kW]} \cdot 9550}{n_L \text{ [1/min]}} \cdot K$$

In calculating the operating torque the appropriate factors should be incorporated:

Type of load	Load factor K
no shock	1,0
moderate shock	1,8
heavy shock	2,5
heavy reversing shock	3,0

Calculation example and coupling selection:

The drive is from an electric motor without shock.
The input power is 1,5 kW at 2750 1/min.

$$T_A = 9550 \cdot \frac{1,5}{2750} = \underline{\underline{5,21 \text{ Nm}}}$$

$$T_L = 9550 \cdot \frac{1,5}{2750} \cdot 1,0 = \underline{\underline{5,21 \text{ Nm}}}$$

Selected coupling: IKT 38.58

Explanation:

T_A [Nm]	= drive torque
T_L [Nm]	= load torque
P_A [kW]	= input power at the coupling
P_L [kW]	= load power at the coupling
n_A [1/min]	= input speed
n_L [1/min]	= load speed
K	= load factor

Misalignment:

The axial, radial and angular misalignment values must be under the permissible values from the data table (see pages 07-09).

For combined radial and angular misalignment the following condition must be satisfied:

$$\frac{\Delta R}{R} + \frac{\Delta \alpha}{\alpha} \leq 1$$

Continuations of example calculation:

Expected misalignment:

in axial direction 0,5mm
in radial direction 0,8mm
in angular direction 0,7°

$$\Delta X = 0,5\text{mm} \leq X = 1\text{mm} \quad \text{OK}$$

$$\Delta R = 0,8\text{mm} \leq R = 1,5\text{mm} \quad \text{OK}$$

$$\Delta \alpha = 0,7^\circ \leq \alpha = 1,5^\circ \quad \text{OK}$$

$$\frac{0,8}{1,5} + \frac{0,7}{1,5} \leq 1 \quad \text{OK}$$

The selected coupling can be used.

R [mm]	= permissible radial misalignment
ΔR [mm]	= existing radial misalignment
α [°]	= permissible angular misalignment
$\Delta \alpha$ [°]	= existing angular misalignment

Technical information

Inkoturn couplings IKT

Assembly:

To achieve problem-free running of the Inkoturn coupling the connected input and output shafts must be adequately supported in rolling bearings (see fig.).

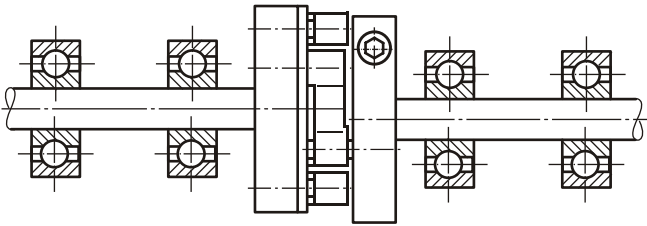

If the Inkoturn coupling is mounted on to two fixed output shafts then the central disc will automatically take up its position regardless of the level of radial or angular misalignment between the shafts. The Inkoturn coupling is maintenance free and can be installed as a complete assembly or as individual parts. The recommended angular, axial and radial misalignment values between the shafts must not be exceeded, as this can lead to excessive wear and premature failure. The performance data for the Inkoturn coupling has been derived from empirical determined values. For special applications please consider operating and site conditions.

The coupling must be protected from water, dust or dirt ingress.

Temperature range:

Inkoturn couplings are suitable with continuous operation for a temperature range from -30°C to +80°C.

Dimensions for IKT single design

Inkoturn couplings IKT

The INKOMA Inkoturn coupling IKT single disc design is available as standard in the following version.

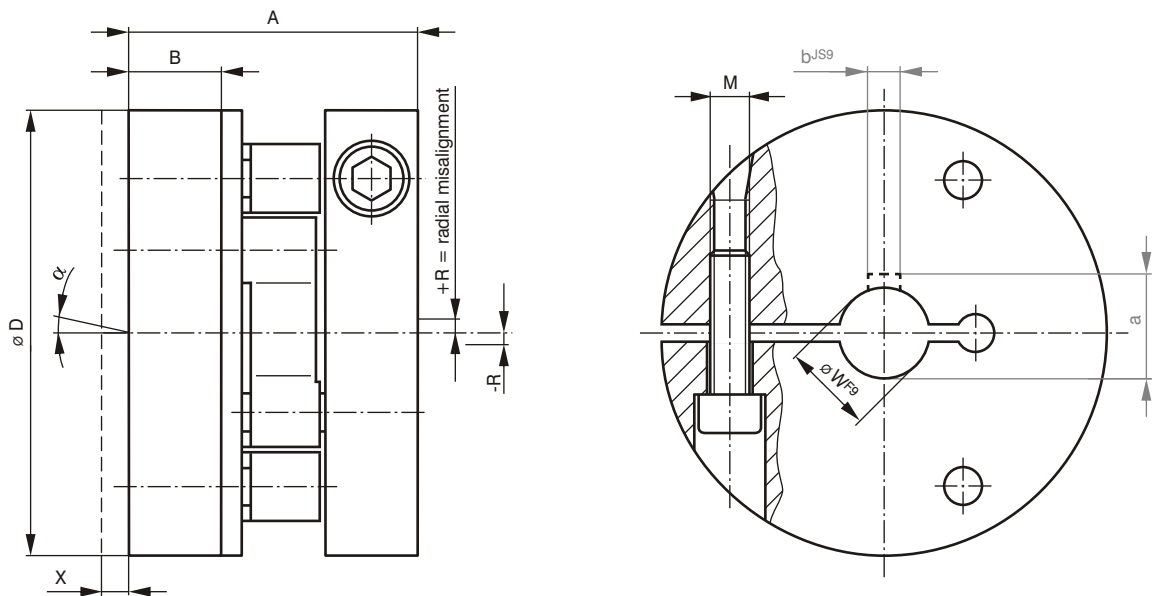

Ordering example:

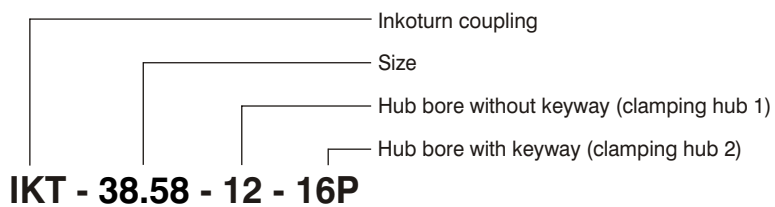

Order code	Dimensions [mm]												
	A	B	D	W ^{1) 2)}	W _{max}	a	b	Thread M					
IKT-16.19	16	5,6	19	6	10	7	2	UNC 2-56x6					
IKT-21.25	20,5	7	25	6	12	7	2	M2,5					
IKT-25.25	25,5	9,5	25	6	11	7	2	M3					
IKT-24.37	24	7	37	8	21	9	2	M3					
IKT-30.37	30	10	37	8	20	9	2	M4					
IKT-38.58	39	12	58	12	32	13,8	4	M5					
IKT-45.58	45	15	58	12	32	13,8	4	M6					
IKT-57.75	57	18	75	16	40	18,3	5	M8					

Order code	Operational data							Mass [kg]				
	Axial misalignment	Radial misalignment	Angular misalignment	Static torque	Maximum torque	Maximum speed ²⁾	Moment of inertia					
	X [mm]	±R [mm]	α [°]	T _{stat} [Nm]	T _{max} [Nm]	n _{max} [1/min]	J [kg cm ²]					
IKT-16.19	0,3	0,4	1,5	0,35	0,8	10.000	0,005	0,01				
IKT-21.25	0,6	1	1,5	0,8	1,2	10.000	0,02	0,02				
IKT-25.25	0,6	1	1,5	0,8	1,2	10.000	0,02	0,03				
IKT-24.37	0,8	1	1,5	2,2	3,3	10.000	0,08	0,05				
IKT-30.37	0,8	1	1,5	2,2	3,3	10.000	0,11	0,06				
IKT-38.58	1,0	1,5	1,5	7,5	10,5	10.000	0,83	0,19				
IKT-45.58	1,0	1,5	1,5	7,5	10,5	10.000	1,0	0,23				
IKT-57.75	1,7	2	1,5	16	24	10.000	3,7	0,50				

¹⁾ The clamping hub can be manufactured to customer specification.

For example the hub can be machined as clamping hub with a parallel keyway, as a two parted hub or to customers specification.

²⁾ For speeds above 1500 1/min the coupling must be statically and dynamically balanced

The connection for the coupling is very flexible. Examples are shown on page 10.
Special sizes are available upon request.

Dimensions for IKT double design

Inkoturn couplings IKT

The INKOMA Inkoturn coupling IKT double disc design is available as standard in the following version.

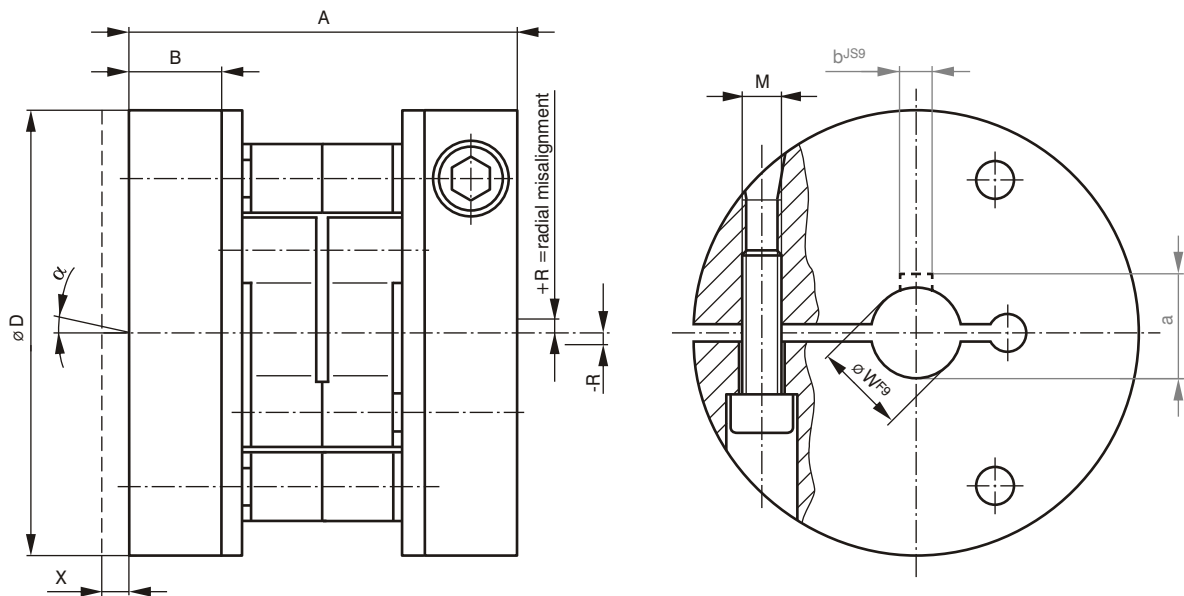

Ordering example:

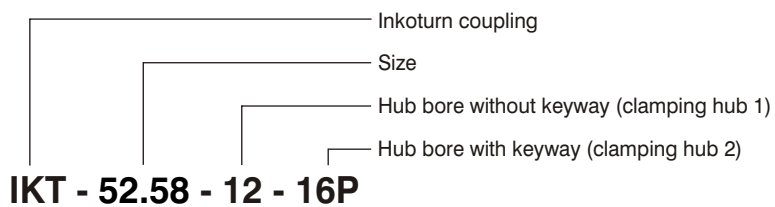

Order code	Dimensions [mm]												
	A	B	D	W ¹⁾	W _{max}	a	b	Thread M					
IKT-20.19	20	5,6	19	6	10	7	2	UNC 2-56x6					
IKT-26.25	26	7	25	6	12	7	2	M2,5					
IKT-31.25	31	9,5	25	6	11	7	2	M3					
IKT-32.37	32	7	37	8	21	9	2	M3					
IKT-38.37	38	10	37	8	20	9	2	M4					
IKT-52.58	52	12	58	12	32	13,8	4	M5					
IKT-58.58	60	15	58	12	32	13,8	4	M6					
IKT-73.75	73	18	75	16	40	18,3	5	M8					

Order code	Operational data							Mass [kg]				
	Axial misalignment X [mm]	Radial misalignment ±R [mm]	Angular misalignment α [°]	Static torque T _{stat} [Nm]	Maximum torque T _{max} [Nm]	Maximum speed ²⁾ n _{max} [1/min]	Moment of inertia J [kg cm ²]					
IKT-20.19	0,3	0,4	1,5	0,7	1,6	10.000	0,005	0,01				
IKT-26.25	0,6	1	1,5	1,6	2,4	10.000	0,02	0,02				
IKT-31.25	0,6	1	1,5	1,6	2,4	10.000	0,02	0,03				
IKT-32.37	0,8	1	1,5	4,4	6,6	10.000	0,1	0,05				
IKT-38.37	0,8	1	1,5	4,4	6,6	10.000	0,1	0,07				
IKT-52.58	1,0	1,5	1,5	15	21	10.000	0,9	0,21				
IKT-58.58	1,0	1,5	1,5	15	21	10.000	1,1	0,26				
IKT-73.75	1,7	2	1,5	32	48	10.000	4,0	0,54				

¹⁾ The clamping hub can be manufactured to customer specification.

For example the hub can be machined as clamping hub with a parallel keyway, as a two parted hub or to customers specification.

²⁾ For speeds above 1500 1/min the coupling must be statically and dynamically balanced

The connection for the coupling is very flexible. Examples are shown on page 10.
Special sizes are available upon request.

Examples

for possible special designs

Use of different hub diameters



Direct connection of the central disc to customers machine or shaft

e.g. spline shaft or polygon shaft

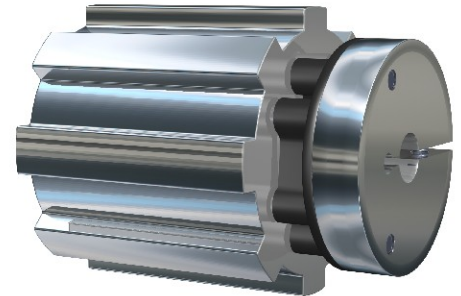

Enlargement of axial length

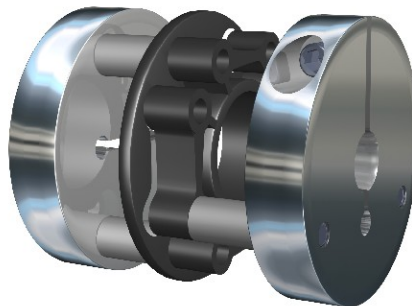

Connection of adaptors

e.g. for particularly large diameters or special profiles

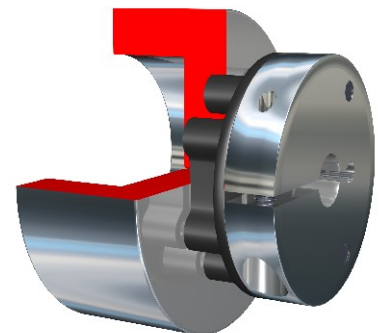

Use of long hubs

