

Product description

Cruciform disc coupling KSO (Oldham design)

INKOMA-KSO-Oldham couplings are machine elements for the smooth transmission of torque between input and output. The coupling can accommodate parallel off-set of the connected shafts as well as angular deviation. The values for the deviations during operation must remain within the permitted limiting values for the coupling.

INKOMA - GROUP
Couplings

by

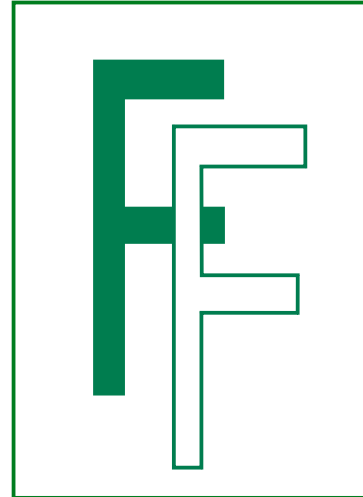



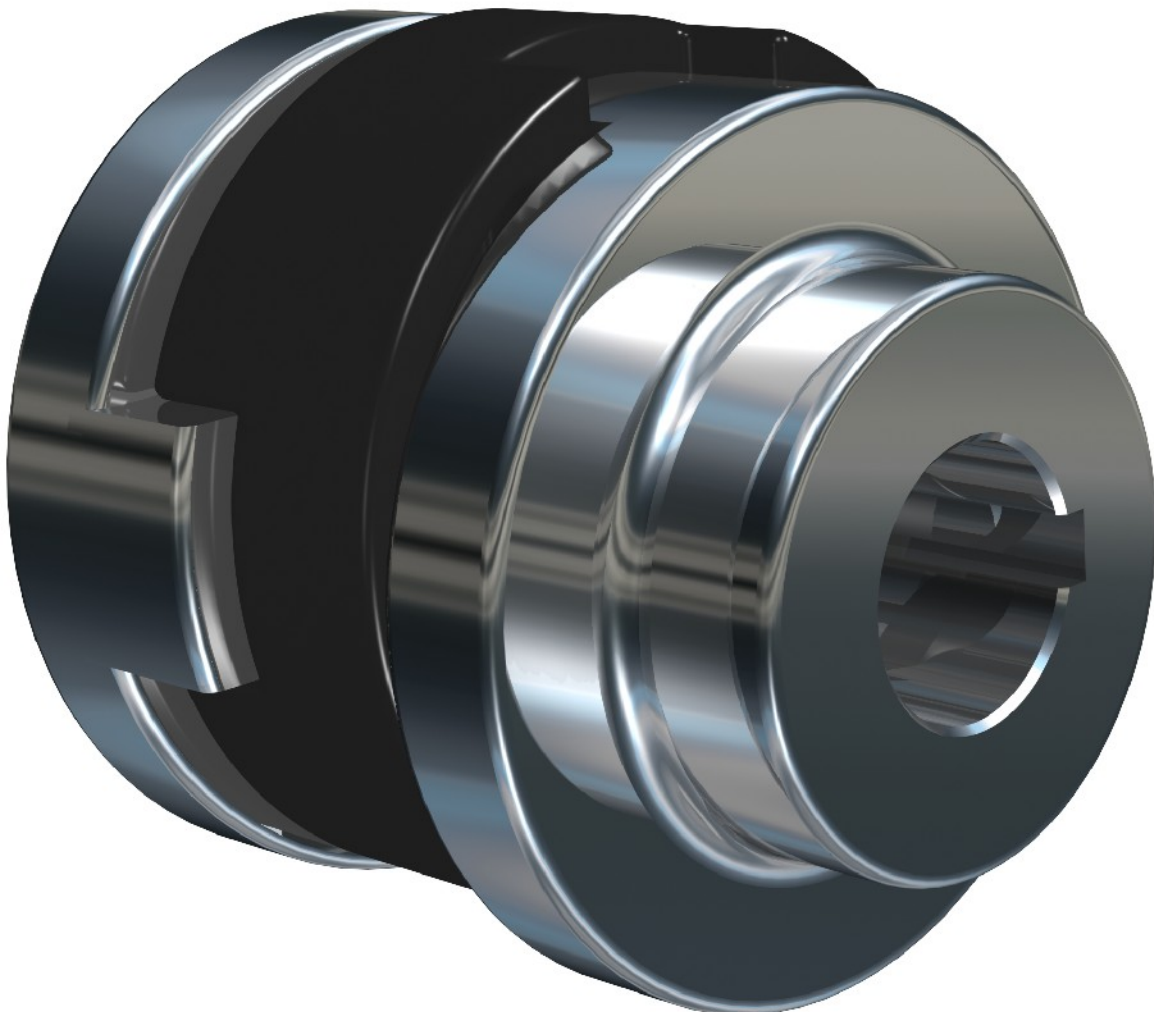



FRANCIS AND FRANCIS Ltd.
www.powertransmissions.co.uk

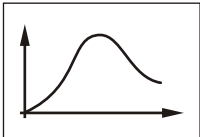
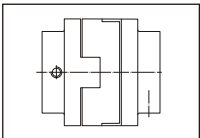
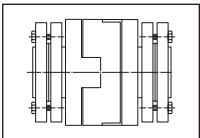

Contents list

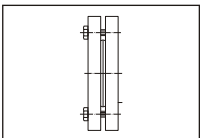
KSO couplings

		Technical Information versions A1, A2, A3, A7	page 003
		Technical Information coupling selection and specification configuration and function assembly	page 004 - 005
		Dimensions versions A1, A2	page 006 - 007
		Dimensions versions A3, A7	page 008 - 009
		Dimensions for ISR-A - Inkofix tension flange/ ISS-A - Inkofix shrink disc for version A3	page 010 - 011

Technical information

KSO couplings

INKOMA-KSO coupling is available in the following versions:

A1 = Flange version:

Both outer discs have fixing holes for socket head cap screws for connecting components. On pitch circle "C" there are four fixing holes.

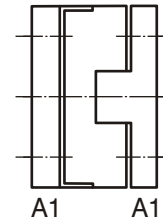

A2 = Hub version:

Both outer discs have finished bores in outward facing hubs and keyways to BS 4235 (DIN 6885/1).

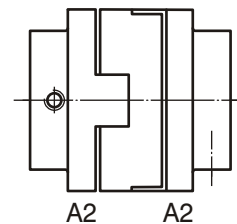

A3 = Tension hub version:

Hub version A2 with additional shrink disc. The shrink disc allows keyless fitting to the shaft. For details of the tension flange see page 10.

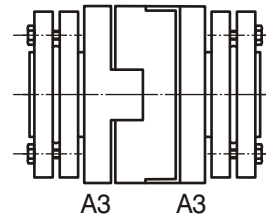

A7 = Split hub version:

This hub version has two components - a fixed and a removable part allowing radial clamping to the shaft, it also has a keyway to BS 4235 (DIN 6885/1). This version requires no axial displacement of the shaft for assembly and disassembly.

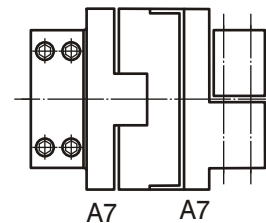

Combinations:

Each coupling can combine any of these versions. E.g. A1/A2 - one side with flanged version with fixing holes for socket head cap screws and the other side with outward facing bored hub with keyway to BS 4235 (DIN 6885).

All versions may be combined with one another, e.g. A1/A3, A2/A7, A2/A3, etc.

Special versions:

In addition to basic versions, customer specific executions are also possible e.g. incorporating sprocket, gears, shaft, etc. in the outer discs.

Technical information

KSO couplings

Coupling selection and specification:

The permitted max. torque of the coupling should always be greater than the nominal torque of the loaded components.

Drive torque:

$$T_A \text{ [Nm]} = \frac{P_A \text{ [kW]} \cdot 9550}{n_A \text{ [1/min]}}$$

Load torque:

$$T_L \text{ [Nm]} = \frac{P_L \text{ [kW]} \cdot 9550}{n_L \text{ [1/min]}} \cdot K$$

In calculating the operating torque the appropriate factors should be incorporated:

Type of load	Load factor K
no shock	1,0
moderate shock	1,8
heavy shock	2,5
heavy reversing shock	3,0

Calculation example and coupling selection:

The drive is from a diesel engine with moderate shock.

The input power is 3 kW at 280 1/min.

$$T_A \text{ [Nm]} = 9550 \cdot \frac{3 \text{ [kW]}}{280 \text{ [1/min]}} = \underline{\underline{102,3 \text{ Nm}}}$$

$$T_L \text{ [Nm]} = 9550 \cdot \frac{3 \text{ [kW]}}{280 \text{ [1/min]}} \cdot 1,8 = \underline{\underline{184,2 \text{ Nm}}}$$

Selected Coupling: KSO-105

Explanation:

T_A [Nm]	= drive torque
T_L [Nm]	= load torque
P_A [kW]	= input power at the coupling
P_L [kW]	= load power at the coupling
n_A [1/min]	= input speed
n_L [1/min]	= load speed
K	= load factor

Configuration and function:

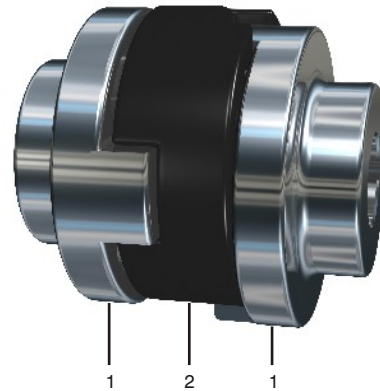

Configuration:

A number of variants on the basic design are possible. The coupling comprises two outer discs "1" and a central coupler disc "2" having machined slots offset 90° on its opposing sides. Dependent on the degree of radial or angular offset or misalignment, small or large oscillating motion will occur through each revolution. This permits relatively large shaft rotational errors to be tolerated.

Special sizes and special versions can be supplied. Please speak to our technical personnel.

The INKOMA-KSO-Oldham coupling has the following important features:

- torsionally stiff connection with shaft offset and angular misalignment compensation,
- synchronous function with radial offset, ie. no angular error per revolution (no phase displacement),
- very high torque transmission from an extremely compact unit,
- simple assembly and dis-assembly,
- simple and economic replacement of the wear component (central coupler).
- good dry running characteristics due to careful material matching,
- rust free versions available.

Technical information

KSO couplings

Assembly:

To achieve problem-free function for the KSO-Oldham coupling the connected input and output shafts must be adequately supported in rolling bearings (see fig. 1). It is dangerous to install the KSO-Oldham couplings in tandem since the coupling could slip out of connection.

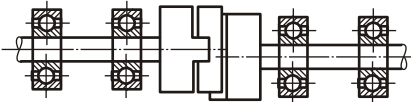

Fig. 1

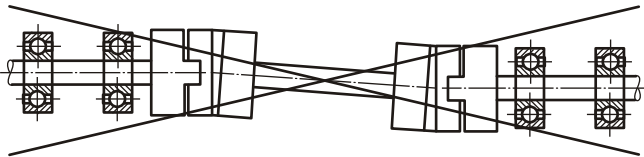
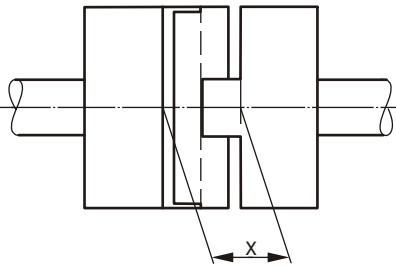

Fig. 2

If the KSO-Oldham coupling is assembled to fixed but offset input and output shafts, the central coupler automatically adopts the position appropriate to the offset (radial or angular displacement). Since the central coupler assumes a slight oscillation during operation, it must be ensured that it has a small axial clearance to allow for this movement. The listed angular and radial offset values only apply when the coupling installation value X is applied.



KSO	6	9	13	19	25	41	60	75	105	125	150	175
"X"	5,2	5,2	7,4	9,5	11,4	17,7	26	31	40	50	66	84

Temperature range:

KSO-Oldham couplings having a plastic central coupler, are suitable for temperatures between -20°C and +60°C. Versions having a bronze disc are suitable for temperatures between -5°C and +70°C. Please consult us if your operational temperatures lie outside these ranges.

Dimensions KSO A1, A2

KSO Oldham coupling

The INKOMA-KSO Oldham coupling is normally available in the following versions:

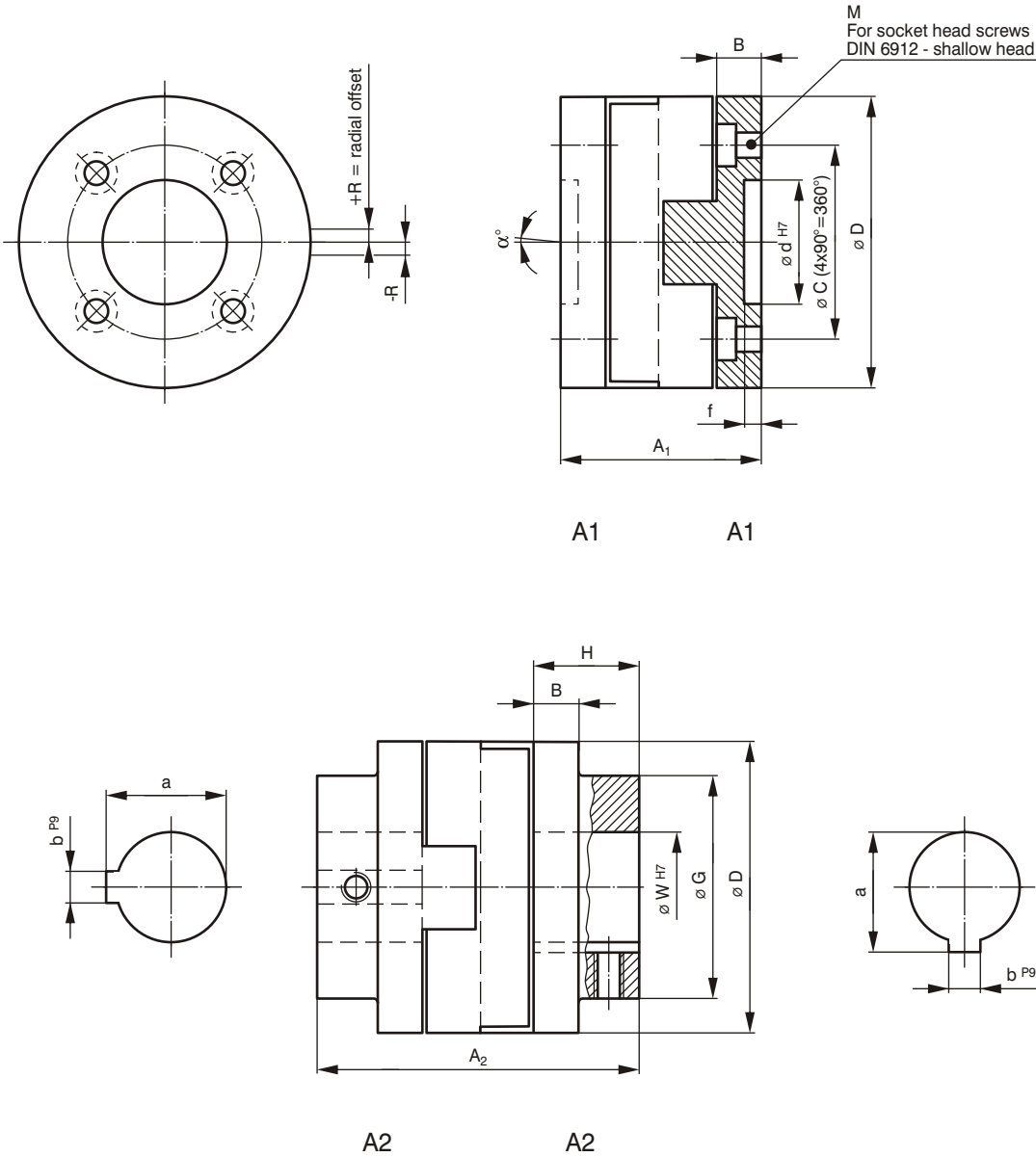

Ordering example:

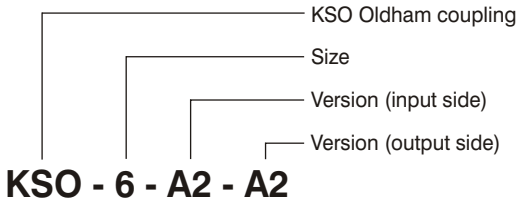

Order code	Dimensions [mm]														
	A ₁	A ₂	B	C	D	G	H	M	W	W _{min}	W _{max}	a	b	d	f
KSO-6	-	13	-	-	6,4	-	3,8	-	3	2	3	-	-	-	-
KSO-9	-	13	-	-	9,5	-	3,8	-	4	3	5	-	-	-	-
KSO-13	-	16	-	-	13	-	4,3	-	5	3	6,3	-	-	-	-
KSO-19	-	23	-	-	19	-	6,3	-	6	4	8	-	-	-	-
KSO-25	-	29	-	-	25,4	-	10,6	-	9	6	12	10,4	3	-	-
KSO-33	-	48	-	-	33	-	15	-	10	8	16	11,4	3	-	-
KSO-41	-	51	-	-	41	-	13,8	-	12	9,5	20	13,8	4	-	-
KSO-60	46	66	10	45	60	-	20	M6	16	-	25	18,3	5	25	3
KSO-75	52	82	10	56	75	-	25	M6	20	-	30	22,8	6	35	3
KSO-105	67	117	13	70	105	80	38	M8	28	-	40	31,3	8	45	5
KSO-125	90	140	20	90	125	80	45	M12	40	-	50	43,3	12	50	6
KSO-150	111	190	22,5	110	150	100	62	M12	50	-	60	53,8	14	55	6
KSO-175	134	234	25	135	175	120	75	M12	60	-	80	64,4	18	60	6
KSO-200	1)	1)	1)	1)	200	1)	1)	1)	1)	-	1)	1)	1)	1)	1)
KSO-250	1)	1)	1)	1)	250	1)	1)	1)	1)	-	1)	1)	1)	1)	1)
KSO-300	1)	1)	1)	1)	300	1)	1)	1)	1)	-	1)	1)	1)	1)	1)

1) Hub length, diameter and bore to customer's specification.

Order code	Operational data						Material		Mass ³⁾ [kg]	CAD-No.: ⁷⁾
	Radial offset $\pm R$ [mm]	Angular misalignment $\pm \alpha$ [°]	Static torque $T_{stat.}$ [Nm]	Inertia ³⁾ J [kg cm ²]	Maximum operating speed ⁴⁾ n_{max} [1/min]	Torsional stiffness ⁵⁾ [Nm/rad]	Outer disc	Central coupler		
KSO-6	0,15	0,5	0,8	0,0006	3000	10	Al	Azetal ⁶⁾	0,003	45000
KSO-9	0,15	0,5	3	0,0018	3000	30	Al	Azetal ⁶⁾	0,006	45030
KSO-13	0,15	0,5	5	0,0026	3000	65	Al	Azetal ⁶⁾	0,013	45060
KSO-19	0,2	0,5	12	0,0067	3000	115	Al	Azetal ⁶⁾	0,015	45090
KSO-25	0,25	0,5	15	0,0255	3000	205	Al	Azetal ⁶⁾	0,034	45120
KSO-33	0,25	0,5	50	0,1140	3000	620	Al	Azetal ⁶⁾	0,075	45150
KSO-41	0,25	0,5	55	0,3327	3000	1200	Al	Azetal ⁶⁾	0,16	45180
KSO-60	0,25	0,5	65	1,2410	3000	2620	Al	PA-GV	0,22	45210
KSO-75	0,5	1	80	16,050	1500	8050	St	PA-GV	2,4	45240
KSO-105	0,5	1	480	79,100	500	13200	St	PA-GV	4,2	45270
KSO-125	0,5	1	700 ²⁾	185,07	500	23100 ²⁾	St	Bz	13,3	45300
KSO-150	1	1,5	910 ²⁾	397,00	500	31000 ²⁾	St	Bz	19,6	45330
KSO-175	1	1,5	1200 ²⁾	721,30	350	40500 ²⁾	St	Bz	28,5	45360
KSO-200	1	1,5	2100	-	300	-	St	-	-	-
KSO-250	2	1,5	5100	-	300	-	St	-	-	-
KSO-300	2,5	1,5	10000	-	300	-	St	-	-	-

²⁾ These values are valid for KSO with a bronze central coupler.

³⁾ for version A2 - A2

⁴⁾ Dependent on offset, angular misalignment and lubrication. Please consult us about higher speeds.

⁵⁾ These values apply for 50% of the static torque, without angular or radial offset.

⁶⁾ Please enquire about other materials.

⁷⁾ The drawing data for sizes 6 to 41 is based on version A2 - A2. For sizes 60 and above the version A1 - A1 applies.

For all other versions the drawing data must be derived.

Dimensions KSO A3, A7

KSO Oldham coupling

The INKOMA-KSO Oldham coupling is normally available in the following versions:

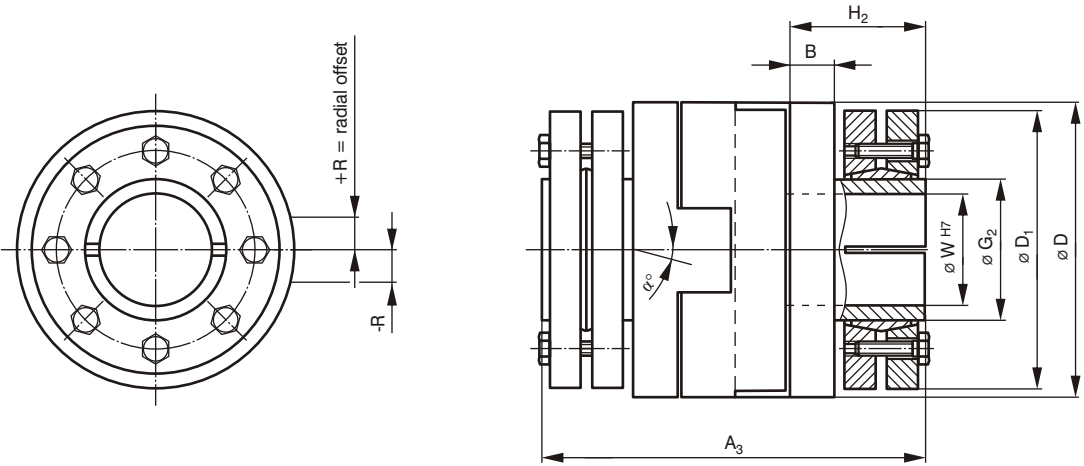

A3 A3
 A3 = A2 + tension flange
 For further details see page 10.

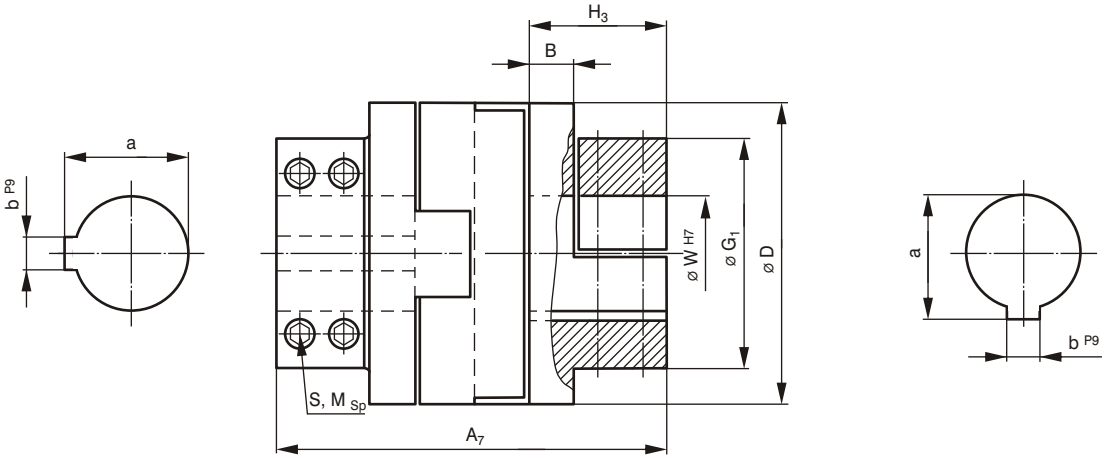

A7 A7

Ordering example:

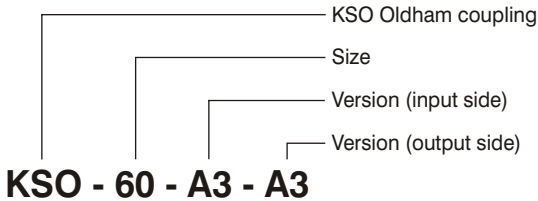

Order code	Dimensions [mm]													
	A ₃	A ₇	B	D	D ₁	G ₁	G ₂	H ₂	H ₃	W	W _{min}	W _{max}	a	b
KSO-6	-	-	-	-	-	-	-	-	-	-	-	-	-	-
KSO-9	-	-	-	-	-	-	-	-	-	-	-	-	-	-
KSO-13	-	-	-	-	-	-	-	-	-	-	-	-	-	-
KSO-19	-	23 ⁸⁾	-	19	-	-	-	-	6,3	6	4	8	-	-
KSO-25	-	29 ⁸⁾	-	25,4	-	-	-	-	8,6	9	6	12	10,4	3
KSO-33	-	48 ⁸⁾	-	33	-	-	-	-	13	10	8	16	11,4	3
KSO-41	-	51 ⁸⁾	-	41	-	-	-	-	16,7	12	9,5	20	13,8	4
KSO-60	82	104	10	60	45	54	18	28	39	16	-	25	18,3	5
KSO-75	92	114	10	75	50	60	24	30	41	20	-	30	22,8	6
KSO-105	123	147	13	105	72	80	36	41	53	28	-	40	31,3	8
KSO-125	160	180	20	125	90	110	50	55	65	40	-	50	43,3	12
KSO-150	191	222	22,5	150	110	120	62	62,5	78	50	-	60	53,8	14
KSO-175	214	264	25	175	120	120	68	65	90	60	-	80	64,4	18
KSO-200	1)	1)	1)	200	1)	1)	1)	1)	1)	1)	-	1)	1)	1)
KSO-250	1)	1)	1)	250	1)	1)	1)	1)	1)	1)	-	1)	1)	1)
KSO-300	1)	1)	1)	300	1)	1)	1)	1)	1)	1)	-	1)	1)	1)

1) Hub length, diameter and bore to customer's specification.

8) A7 - version with single sided split (clamp hub)

Order code	Clamping screws A ₇		Operational data						Material		Mass ³⁾ [kg]	CAD-No.: ⁷⁾	
	S	Tightening torque M _{Sp} [Nm]	Radial offset ±R [mm]	Angular misalignment ±α [°]	Static torque T _{stat.} [Nm]	Inertia ³⁾ J [kg cm ²]	Maximum operating speed ⁴⁾ n _{max} [1/min]	Torsional stiffness ⁵⁾ [Nm/rad]	Outer disc	Central coupler			
KSO-6	-	-	-	-	-	-	-	-	-	-	-	-	-
KSO-9	-	-	-	-	-	-	-	-	-	-	-	-	-
KSO-13	-	-	-	-	-	-	-	-	-	-	-	-	-
KSO-19	1xM3	2,4	0,2	0,5	12	0,0067	3000	115	Al	Azetal ⁶⁾	0,015	45090	
KSO-25	1xM3	2,5	0,25	0,5	15	0,0255	3000	205	Al	Azetal ⁶⁾	0,034	45120	
KSO-33	1xM3	2,5	0,25	0,5	50	0,1140	3000	620	Al	Azetal ⁶⁾	0,075	45150	
KSO-41	1xM4	5,7	0,25	0,5	55	0,3327	3000	1200	Al	Azetal ⁶⁾	0,16	45180	
KSO-60	4xM5	6	0,25	0,5	65	1,2410	3000	2620	Al	PA-GV	0,22	45210	
KSO-75	4xM6	10,5	0,5	1	80	16,050	1500	8050	St	PA-GV	2,4	45240	
KSO-105	4xM8	25	0,5	1	480	79,100	500	13200	St	PA-GV	4,2	45270	
KSO-125	4xM10	50	0,5	1	700 ²⁾	185,07	500	23100 ²⁾	St	Bz	13,3	45300	
KSO-150	4xM12	87	1	1,5	910 ²⁾	397,00	500	31000 ²⁾	St	Bz	19,6	45330	
KSO-175	4xM12	87	1	1,5	1200 ²⁾	721,30	350	40500 ²⁾	St	Bz	28,5	45360	
KSO-200	1)	1)	1	1,5	2100	-	300	-	St	-	-	-	
KSO-250	1)	1)	2	1,5	5100	-	300	-	St	-	-	-	
KSO-300	1)	1)	2,5	1,5	10000	-	300	-	St	-	-	-	

1) Hub length, diameter and bore to customer's specification.

2) These values are valid for KSO with a bronze central coupler.

3) for version A2 - A2

4) Dependent on offset, angular misalignment and lubrication. Please consult us about higher speeds.

5) These values apply for 50% of the static torque, without angular or radial offset.

6) Please enquire about other materials.

7) The drawing data for sizes 6 to 41 is based on version A2 - A2. For sizes 60 and above the version A1 - A1 applies.

For all other versions the drawing data must be derived.

Dimensions

ISR-A - Inkofix tension flange / ISS-A - Inkofix shrink disc

For version A3.

ISR-A - Inkofix tension flange

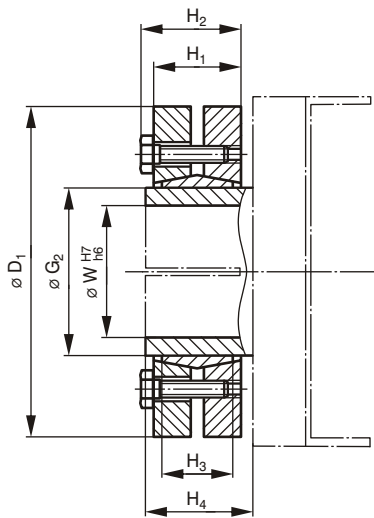

ISS-A - Inkofix shrink disc

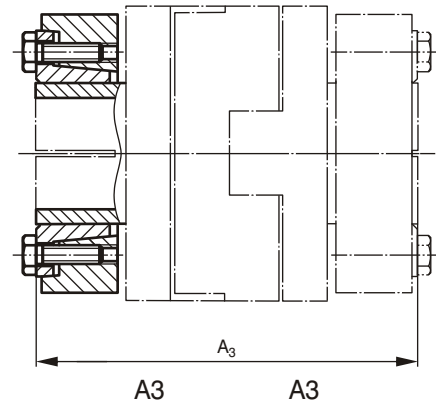
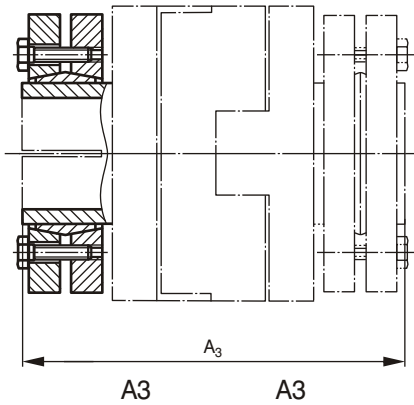
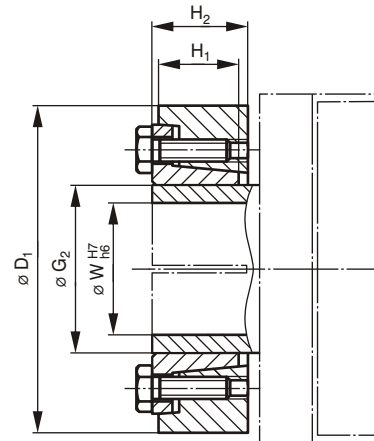

Explanation:

$T_{stat.}$ = maximum transmissible torque for tension flange
 F_{ax} = maximum transmissible axial force for tension flange
 T_A = required tightening torque of the tension screws

Ordering example:

ISR 50 . 90 / A

Legend:

- ISR: Inkofix tension flange
- 50: Internal diameter W
- 90: Outer diameter D_1
- A: Version

Order code Coupling	Order code Tension flange	Dimensions [mm]							Tension screw		Operational data			Mass [kg]	CAD-No.:
		D ₁	G ₂	H ₁ ¹⁾	H ₂ ¹⁾	H ₃ ¹⁾	H ₄ ¹⁾	W	DIN 931/ ISO 4014 10.9	Tightening torque T _A [Nm]	Torque ³⁾ T _{stat.} [Nm]	max. axial force ³⁾ F _{ax} [kN]	Mass moment of inertia J [kg cm ²]		
KSO-60	ISS 18.45/A	45	18	12	15	-	-	15 - 16	6xM5x12 ²⁾	7	80 - 112	10 - 14	0,4	0,135	
KSO-75	ISR 24.50/A	50	24	18	22	15	20	19 - 22	6xM5x16	7	181 - 236	18 - 22	0,7	0,18	
KSO-105	ISR 36.72/A	72	36	22	26	20	28	28 - 32	6xM6x20	12	448 - 654	32 - 40,8	4,0	0,50	
KSO-125	ISR 50.90/A	90	50	26	30	24	35	38 - 42	8xM6x20	12	966 - 1446	51 - 68	11,0	0,80	
KSO-150	ISR 62.110/A	110	62	32	36	28	40	49 - 52	10xM6x25	12	1820 - 2300	75 - 88	30,0	1,50	
KSO-175	ISR 68.120/A	120	68	36	40	32	40	53 - 60	10xM6x30	32	2400 - 3250	90 - 108	43,0	1,80	

¹⁾ free length in Inkofix tension flange ISR

²⁾ only in the Inkofix shrink disc ISS: DIN 933/ ISO 4017 - 10.9

³⁾ the values for T_{stat.} and F_{ax} vary with W and are derived by interpolation.