

Product description

Lineflex couplings LFK

The INKOMA-Lineflex coupling is a machine component for the transmission of torque between shafts having parallel but offset axes. The amount of offset can be infinitely varied within design limits, both statically and dynamically.

The coupling is similar to the Parallel Off-set coupling (type PK) and comprises three discs. The discs are arranged with their faces parallel and are connected with at least two pairs of links at right angles to each other. This special link arrangement also permits problem-free connection of parallel shafts having zero offset.

One outer disc is fixed to the input shaft and the other outer disc is connected to the output shaft. The third disc sits between the two outer discs and connects them through the links.

Unlike Universal Joints, no rotational variation occurs regardless of the offset. INKOMA-Lineflex couplings can be installed in horizontal or vertical attitudes. They have a high rotational stiffness and synchronicity. Radial oscillations are absorbed.

Features of the INKOMA-Lineflex coupling

INKOMA-Lineflex couplings provide true constant velocity. I.e. Input and output run synchronously regardless of the degree of offset.

INKOMA-Lineflex couplings tolerate radial offset up to the specified values and can also operate with no offset. Offset can be varied dynamically, within the given limits, even at high speeds. Torque loadings, and synchronous running are unaffected.

INKOMA-Lineflex couplings are fully dynamically balanced. Radial oscillations are compensated for and damped.

INKOMA-Lineflex coupling transmit only torque and therefore exert no loads on the shaft bearings.

INKOMA-Lineflex couplings are maintenance free even in continuous operation. The coupling links are fitted with needle roller bearings, and, in extreme cases (totally back-lash free), can be assembled with pre-load.

Special sizes and designs are possible. Please enquire.

INKOMA - GROUP
Couplings

by

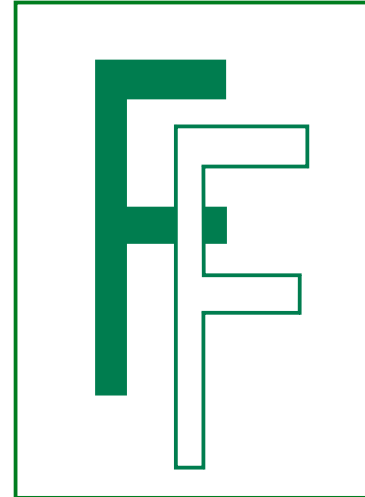



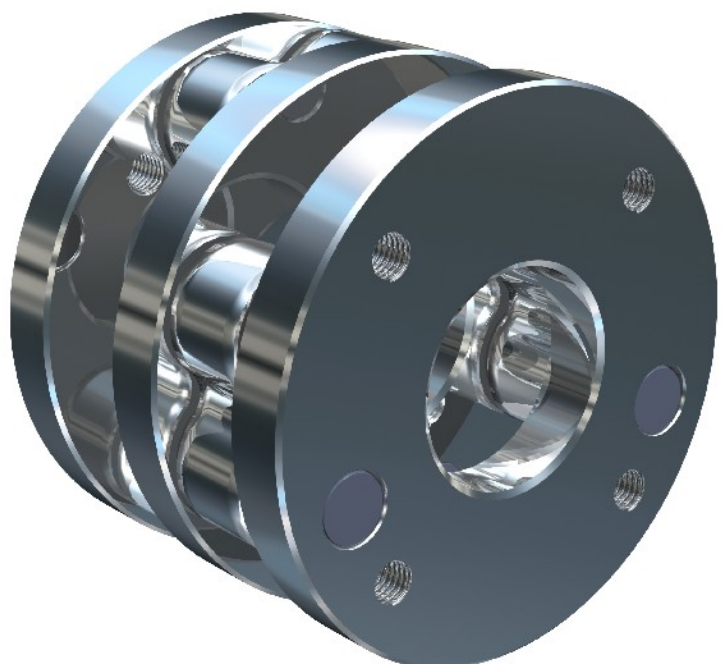





FRANCIS AND FRANCIS Ltd.
www.powertransmissions.co.uk

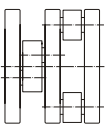

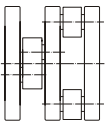
Contents list

Lineflex couplings LFK

		Technical information versions A1, A2 A3, A4, A5, A6, A7	page 003
		Technical information notes for installation and operation coupling selection and specification	page 004 - 005
		Dimensions LFK 44 to LFK 280 Lineflex coupling LFK (A1, A2, A3, A4, A5, A6, A7)	page 006 - 007
		Dimensions LFK 44 to LFK 280 Lineflex coupling LFK (A1, A2, A3, A4, A5, A6, A7)	page 008 - 009
		Selection table torque based life selection table power based life selection table	page 010 - 011
		Dimensions for GFL - separable flange for versions A4 and A6	page 012 - 013
		Dimensions for ISP-D - Inkofix tension flange for version A3	page 014 - 015

Technical information

Lineflex couplings LFK

INKOMA-Lineflex coupling LFK is available in the following versions:

A1= Basic version:

Both outer discs have tapped holes for the mounting of adaptors and hubs.

A2= Hub version:

Both outer discs have finished bores in outward facing hubs.

A3= Tension hub version:

Basic version A1 with additional shrink disc. The shrink disc allows keyless fitting to the shaft.

For details of the tension flange see page 14.

A4= Separable hub version:

Basic version A1 with additional adaptor flanges. These flanges have hubs for shaft fitting.

For details of separable flanges see page 12.

A5= Hub version with inward facing integral hubs:

Both outer discs have finished bores in inward facing hubs. The axial length is the same as basic version A1 - A1.

A6= Separable hub version with inward facing integral hubs:

Basic version A1 with additional inward facing adaptor flanges. For details of separable flanges see page 12.

A7= Split hub version:

This hub version has two components - a fixed and a removable part allowing radial clamping to the shaft. This version requires no axial displacement of the shaft for assembly and disassembly.

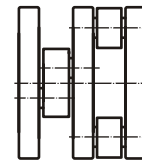

A1 A1

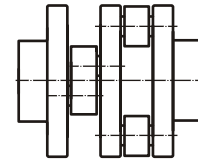

A2 A2

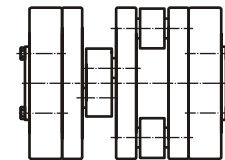

A3 A3

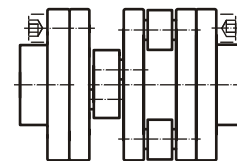

A4 A4

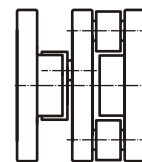

A5 A5

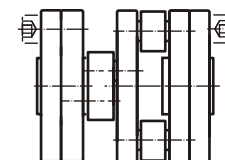

A6 A6

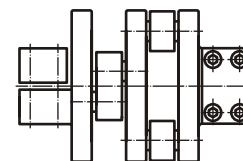

A7 A7

Combinations:

Each coupling can combine any of these versions. E.g. A1/A2 - one disc with tapped holes and the other with outward facing bored hub. All versions may be combined with one another, e.g. A3/A4, A1/A4, A2/A3, etc.

Special versions:

In addition to basic versions, customer specific executions are also possible e.g. incorporating sprocket, gears, shaft, etc. in the outer discs.

Technical information

Lineflex couplings LFK

Notes for installation and operation:

The shafts or components being connected must be assembled with parallel axes. If the recommended angular error α° is exceeded it is strongly recommended that the INKOMA-Inkoflex coupling is used. (See brochure for Inkoflex coupling). Angular errors will lead to adverse loading of the roller bearings and premature wear, leading to failure.

All LFK couplings have axial freedom:

Light series	- couplings having plain bushes	+ 1 mm
Standard series	- up to size LFK 196...	± 2 mm
Heavy duty series	- up to size LFK 280...	± 4 mm

Care should be taken to ensure that the coupling is not under axial tension; it should be possible to feel axial movement at the centre disc. Despite the use of high quality materials we cannot guarantee absolute torsional stiffness. The graph below shows the calculated mean values for torsional stiffness. If extreme torsional stiffness is necessary we suggest that either pre-loading be applied to the bearings or braking is applied to the coupling system. For most applications the torsional stiffness is adequate. Reduction in the bearing clearance reduces the permitted angular misalignment α° .

The INKOMA-Lineflex coupling is fully dynamically balanced and therefore suitable for high rotational speeds. Radial oscillations are absorbed and not transmitted.

The INKOMA-Lineflex coupling is supplied ready for operation. Re-lubrication can be carried out using the grease nipples fitted to each link. The frequency of re-lubrication depends on the grease characteristics, the amount of grease, the speed, the load and environmental effects. These factors must be considered since they can significantly affect performance.

For cases involving moderate speeds and loads the coupling is lubricated for life.

Example:

LFK 134.140/2

$$T_{\text{stat.}} \text{ [Nm]} = 2100 \text{ Nm}$$

$$T_{\text{kN}} \text{ [Nm]} = 660 \text{ Nm}$$

$$T \text{ [%]} = 100 \% \frac{T_{\text{kN}}}{T_{\text{stat.}}}$$

$$T \text{ [%]} = 100 \% \frac{660 \text{ Nm}}{2750 \text{ Nm}} = 24 \% \rightarrow \text{Wind up } \rho = 2,5'$$

$T_{\text{stat.}}$ [Nm] = max. static torque

T_{kN} [Nm] = nominal drive torque

T [%] = torque in % of capacity

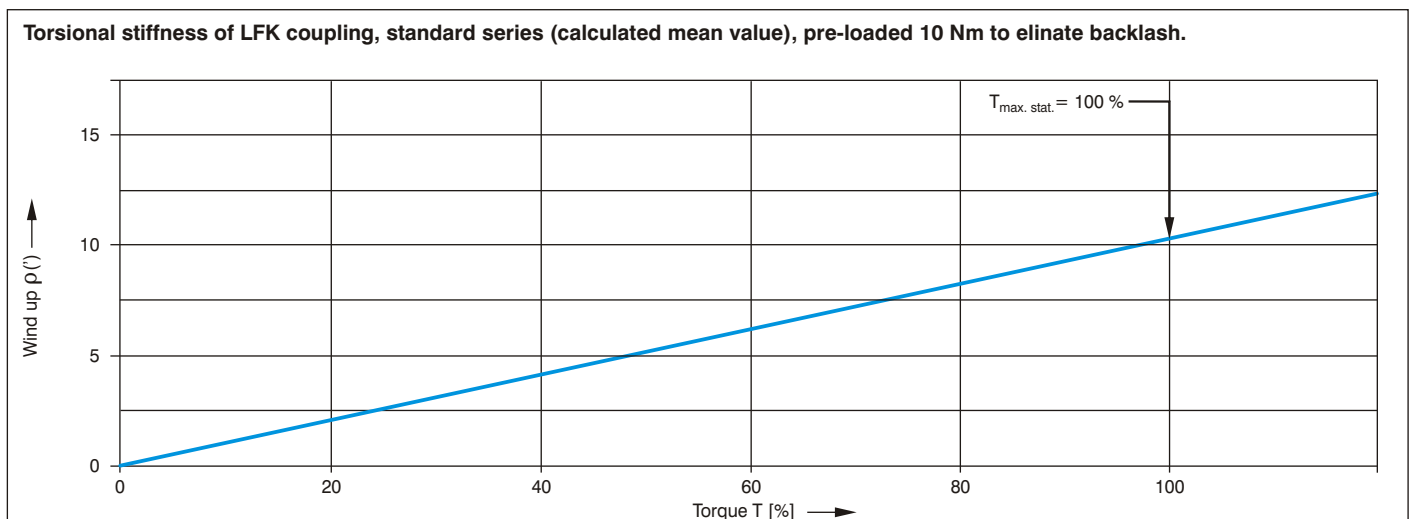

Technical information

Lineflex couplings LFK

Coupling selection and specification:

The load capacity of the INKOMA-Lineflex coupling is dependent on the speed and type of load. The following factors should be applied to the selection process:

Type of load	Load factor K
no shock	1,0
moderate shock	1,8
heavy shock	2,5
heavy reversing shock	3,0

Thus the effective load torque T can be determined

$$T = \frac{9550 \cdot K \cdot P}{n}$$

or using the effective operating power of the drive system.

$$P_B = K \cdot P_A$$

Using the calculated value for torque or power the table on pages 10-11 can be used to select the appropriate INKOMA-Lineflex coupling for the required speed and life.

Example:

a roller drive requires $P = 2,8$ kW,

speed = 150 1/min

heavy shock loading

required life = 20000 h

$$P_B = K \cdot P$$

$$P_B = 2,5 \cdot 2,8 \text{ kW}$$

$$P_B = 7 \text{ kW}$$

Given the values for power, speed and required life, the tables on pages 10 - 11 can be used to select the appropriate INKOMA-Lineflex coupling.

Selected Coupling: LFK 134.140/2

Explanation:

T [Nm] = effective load torque

K [-] = load factor

P [kW] = input power

n [1/min] = speed

P_B [kW] = max. effective power on the coupling

P_A [kW] = input power at the coupling

L_n [h] = required life

Dimensions LFK 44 to LFK 280

Lineflex coupling LFK (A1, A2)

The INKOMA-Lineflex coupling is normally available in the following versions:

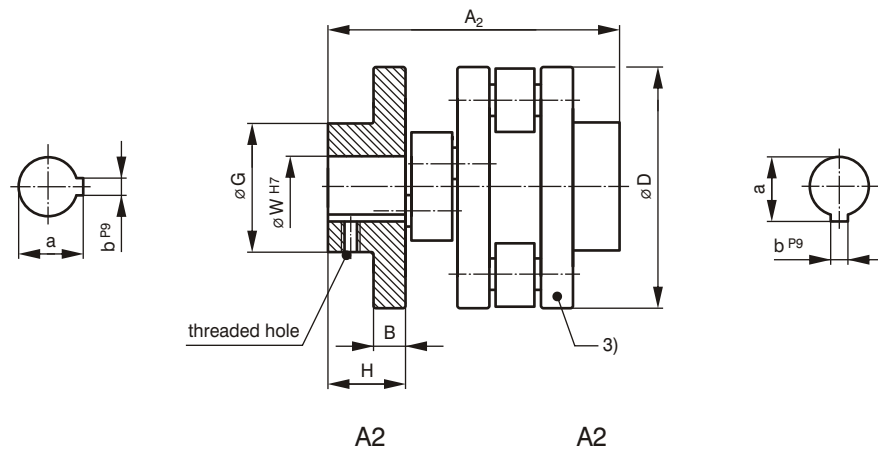
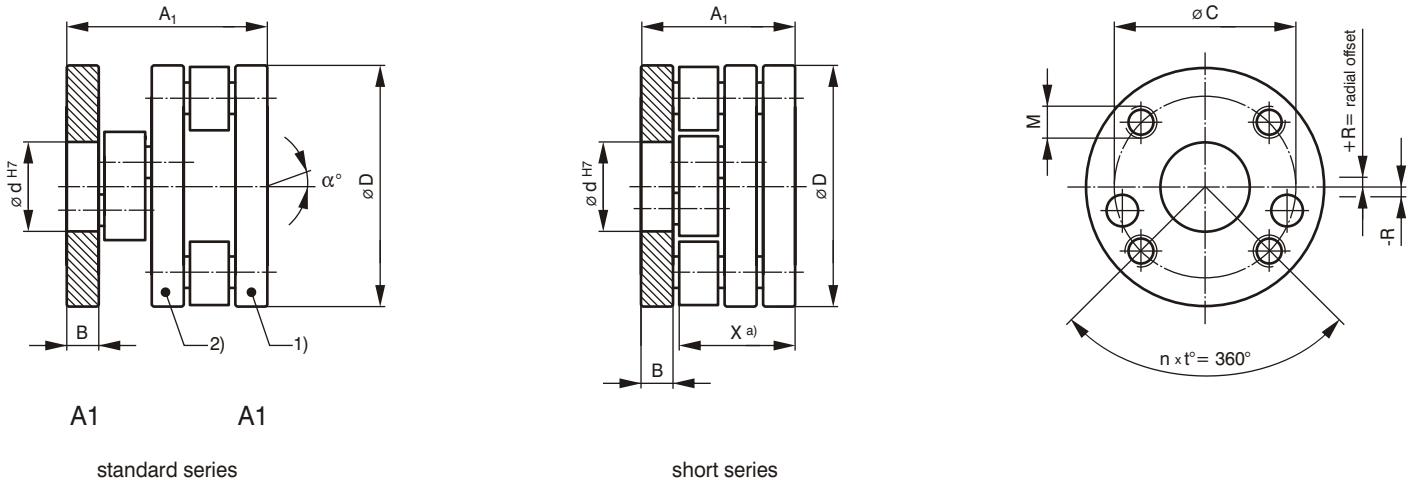

- 1) outer disc
- 2) centre disc
- 3) outer disc with hub
- 4) separable flange with hub
- 5) outer disc with tension flange
- 6) outer disc with split hub

a) "X" this dimension is fixed

Ordering example:

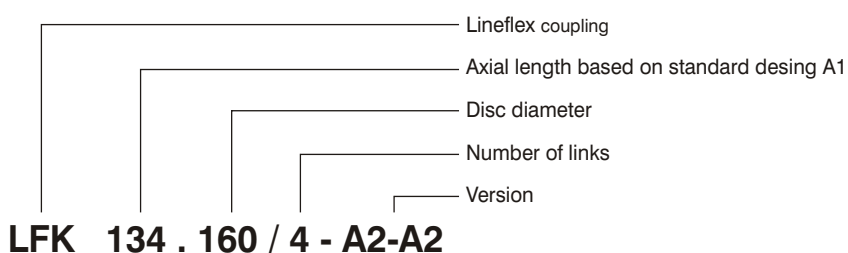

Dimensions LFK 44 to LFK 280

Lineflex coupling LFK (A3, A4, A5, A6, A7)

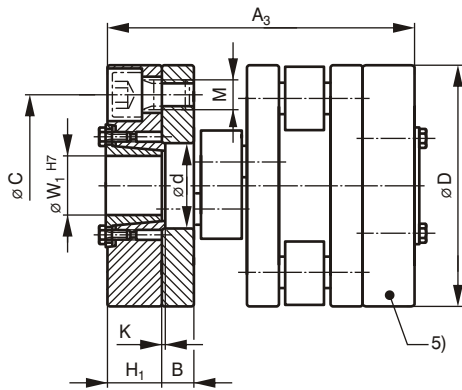

A3

A3

$$A3 = A1 + ISP-D$$

For further details see page 14 tension flange.

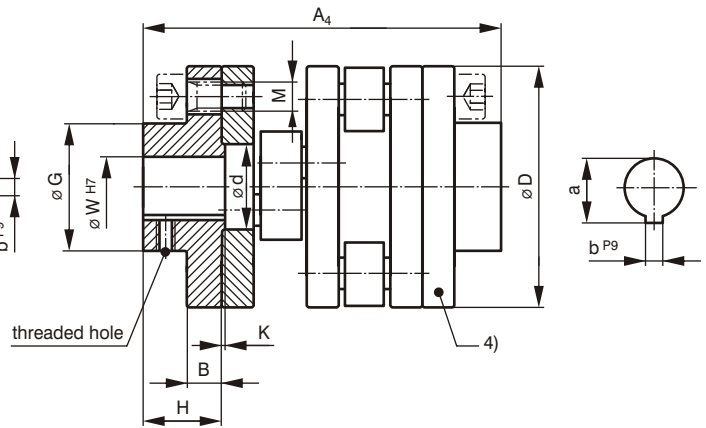

A4

A4

$$A4 = A1 + GFL$$

For missing dimensions and designations for GFL see page 12.

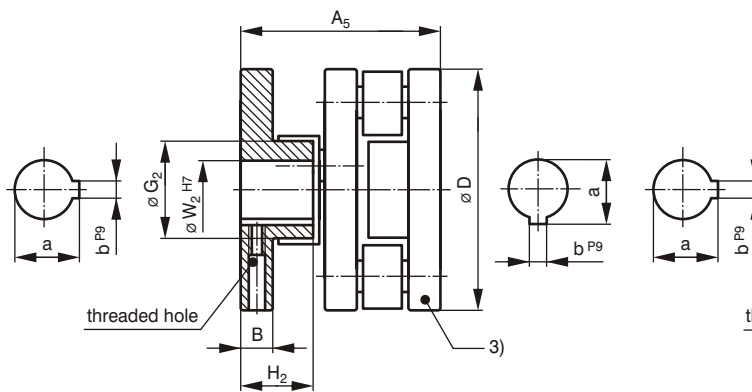

A5

A5

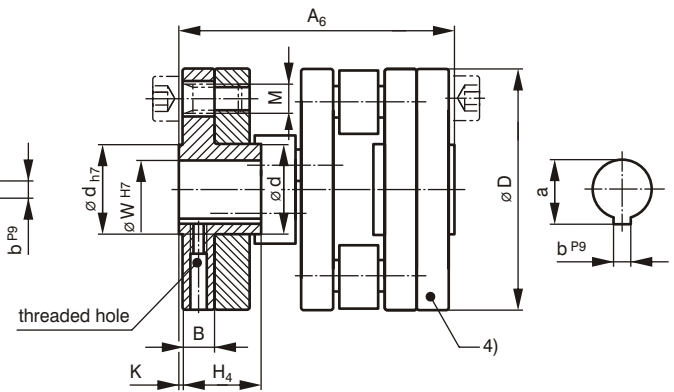

A6

A6

$$A6 = A1 + GFL$$

For missing dimensions and designations for GFL see page 12.

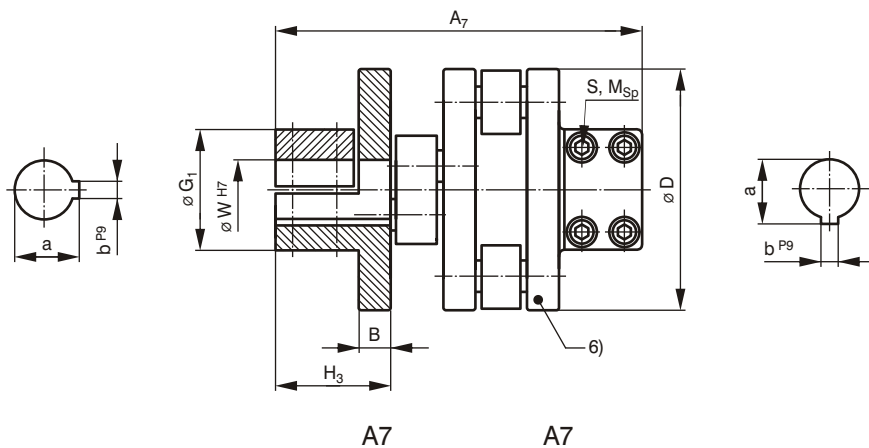

A7

A7

Dimensions LFK 44 to LFK 280

Lineflex coupling LFK (A1, A2, A3, A4, A5, A6, A7)

Order code	Dimensions [mm]																				
	A ₁	A ₂	A ₃	A ₄	A ₅	A ₆	A ₇	B	C	D	G	G ₁	G ₂	H	H ₁	H ₂	H ₃	K	W ^{1,3)}	W ₁ ¹⁾	W ₂ ^{1,3)}
LFK 44.50/2 ⁵⁾	44	68	-	84	44	64	76	8	35	50	28	46	18	20	-	16	24	2	14	-	12
LFK 44.70/2 ⁵⁾	44	68	-	84	44	64	94	8	56	70	35	40	35	20	-	16	33	2	16	-	16
LFK 44.70/2-k ⁵⁾	35	59	-	75	⁴⁾	55	85	8	56	70	35	40	35	20	-	16	33	2	16	-	16
LFK 44.70/4 ⁵⁾	44	68	-	84	-	64	94	8	56	70	35	40	-	20	-	-	33	2	16	-	-
LFK 74.70/2	74	93	-	114	-	99	124	10,5	48	70	35	37,5	-	20	-	-	35,5	2	16	-	-
LFK 74.90/2	74	127	102	148	74	-	134	10,5	70	90	55	50	38	37	14	30	40,5	3	25	25	25
LFK 74.90/2-k	58	111	86	132	⁴⁾	-	118	10,5	70	90	55	50	38	37	14	30	40,5	3	25	25	25
LFK 74.120/2	74	137	122	158	74	101	144	10,5	98	120	60	65	55	42	24	30	45,5	3	30	30	30
LFK 74.120/2-k	58	121	106	142	⁴⁾	85	128	10,5	98	120	60	65	50	42	24	30	45,5	3	30	30	30
LFK 74.120/4	74	137	122	158	74	101	144	10,5	98	120	60	65	50	42	24	30	45,5	3	30	30	30
LFK 74.150/4	74	137	122	158	74	101	173	10,5	128	150	70	70	55	42	24	30	60	3	35	35	35
LFK 74.150/4-k	58	121	106	142	⁴⁾	85	157	10,5	128	150	70	70	55	42	24	30	60	3	35	35	35
LFK 101.100/2	101	144	-	175	-	-	182	15,5	70	100	54	65	-	37	-	-	56	3	30	-	-
LFK 101.120/2	101	154	151	185	101	138	182	15,5	90	120	65	65	50	42	25	30	56	3	30	30	30
LFK 101.120/2-k	78,5	131,5	128,5	162,5	78,5	115,5	159,5	15,5	90	120	65	65	45	42	25	30	56	3	30	30	30
LFK 101.140/2	101	174	161	205	101	138	200	15,5	110	140	70	80	65	52	30	37	65	3	35	35	35
LFK 101.140/2-k	78,5	151,5	138,5	182,5	⁴⁾	115,5	177,5	15,5	110	140	70	80	60	52	30	37	65	3	35	35	35
LFK 134.120/2	134	193	-	238	-	-	234	22,5	90	120	70	78	-	52	-	-	72,5	3	35	-	-
LFK 134.140/2	134	193	204	238	134	-	234	22,5	100	140	70	78	45	52	35	45	72,5	3	35	35	30
LFK 134.140/2-k ⁵⁾	110	169	180	214	110	-	210	22,5	100	140	70	78	45	52	35	45	72,5	3	35	35	30
LFK 134.160/2	134	193	204	238	134	185	244	22,5	120	158	85	90	60	52	35	45	77,5	3	40	40	40
LFK 134.160/2-k	110	169	180	214	110	161	220	22,5	120	158	85	90	60	52	35	45	77,5	3	40	40	40
LFK 155.140/2	155	197	-	247	-	211	265	25	100	140	70	85	-	46	-	-	80	3	30	-	-
LFK 155.160/2	155	209	245	259	155	211	265	25	115	160	75	88	56	52	45	58	80	3	40	40	40
LFK 155.180/2	155	229	245	279	155	211	275	25	135	180	90	100	78	62	45	58	85	3	45	45	45
LFK 155.180/2-k	127	201	217	251	⁴⁾	183	247	25	135	180	90	100	65	62	45	58	85	3	45	45	45
LFK 155.200/2	155	249	265	299	155	211	275	25	152	200	100	100	78	72	55	58	85	3	50	50	50
LFK 155.220/4	155	265	265	315	155	211	305	25	180	220	120	130	65	80	55	58	100	3	55	55	45
LFK 155.250/4	155	265	285	315	155	211	305	25	210	250	120	130	115	80	65	58	100	3	60	60	60
LFK 155.300/4	155	295	285	345	155	211	385	25	260	300	140	150	160	95	65	58	140	3	70	70	70
LFK 155.300/4-k	127	267	257	317	127	183	357	25	260	300	140	150	135	95	65	58	140	3	70	70	70
LFK 196.200/2	196	276	326	336	196	266	346	30	150	200	100	115	85	70	65	68	105	5	50	50	50
LFK 196.250/2	196	296	336	356	196	266	366	30	200	250	120	150	110	80	70	68	115	5	60	60	60
LFK 196.250/4	196	296	336	356	196	266	366	30	200	250	120	150	85	80	70	68	115	5	60	60	60
LFK 196.310/4	196	326	⁶⁾	386	196	266	376	30	260	310	160	170	155	95	75	68	120	5	80	80	80
LFK 196.350/4	196	406	⁶⁾	466	196	266	416	30	280	350	200	210	165	135	80	68	140	5	90	90	90
LFK 196.350/4-k	152	362	⁶⁾	422	152	222	372	30	280	350	200	210	165	135	80	68	140	5	90	90	90
LFK 196.350/6	196	⁶⁾	⁶⁾	⁶⁾	⁶⁾	⁶⁾	⁶⁾	30	280	350	⁶⁾	⁶⁾	⁶⁾	⁶⁾	⁶⁾	⁶⁾	⁶⁾	5	⁶⁾	⁶⁾	⁶⁾
LFK 280.400/4	280	⁶⁾	⁶⁾	⁶⁾	⁶⁾	⁶⁾	⁶⁾	48	⁶⁾	400	⁶⁾	⁶⁾	⁶⁾	⁶⁾	⁶⁾	⁶⁾	⁶⁾	⁶⁾	⁶⁾	⁶⁾	⁶⁾
LFK 280.500/4	280	⁶⁾	⁶⁾	⁶⁾	⁶⁾	⁶⁾	⁶⁾	48	⁶⁾	500	⁶⁾	⁶⁾	⁶⁾	⁶⁾	⁶⁾	⁶⁾	⁶⁾	⁶⁾	⁶⁾	⁶⁾	⁶⁾

-k= short series, dimension "X" is fixed

¹⁾ preferred bore dimension, also available in other diameters

³⁾ keyway to BS 4235 (DIN 6885/1)

⁴⁾ only A1 to A5 versions available for short series

⁵⁾ not fixed axially

⁶⁾ to customer requirement

Axial freedom:

LFK 44...196 ± 2mm

LFK 280 ± 4mm

Special sizes and designs are possible. Please enquire.

Dimensions - Operational data LFK 44 to LFK 280

Lineflex coupling LFK (A1, A2, A3, A4, A5, A6, A7)

Order code	Dimensions			Mounting holes			Clamping screws A7		Operational data				Mass ²⁾ [kg]	CAD-Nr.:
	a [mm]	b [mm]	d [mm]	Thread M	Number n	Hole pitch t [°]	S	Tightening torque M _{Sp.} [Nm]	Radial offset R [±mm]	Angular misalignment α [°]	Torque T _{stat.} [Nm]	Mass moment of inertia ²⁾ J [kg cm ²]		
LFK 44.50/2	16,3	5	22	M6	3	120	2xM5	6	2	0,6	70	1,25	0,34	36001
LFK 44.70/2	18,3	5	25	M6	4	90	4xM5	6	2	0,6	115	4,90	0,75	36100
LFK 44.70/2-k	18,3	5	25	M6	4	90	4xM5	6	2	0,6	115	5,25	0,76	36110
LFK 44.70/4	18,3	5	25	M6	4	90	4xM5	6	2	0,6	165	6,08	0,88	36120
LFK 74.70/2	18,3	5	25	M10	3	120	2xM5	6	3	0,7	320	9	1,3	36150
LFK 74.90/2	28,3	5	45	M10	3	120	4xM6	10,5	3	0,7	463	14,2	1,5	36160
LFK 74.90/2-k	28,3	5	45	M10	3	120	4xM6	10,5	3	0,7	463	15,1	1,6	36170
LFK 74.120/2	33,3	8	50	M10	3	120	4xM8	25	6	0,7	638	60	2,8	36180
LFK 74.120/2-k	33,3	8	50	M10	3	120	4xM8	25	3	0,7	638	62	2,9	36190
LFK 74.120/4	33,3	8	50	M10	3	120	4xM8	25	3	0,7	1085	72	3,3	36200
LFK 74.150/4	38,3	10	60	M12	4	90	4xM8	25	3	0,7	1570	150	4,6	36210
LFK 74.150/4-k	38,3	10	60	M12	4	90	4xM8	25	3	0,7	1570	153	4,7	36220
LFK 101.100/2	33,3	8	40	M16	3	120	4xM8	25	4	0,6	930	46	3,2	36300
LFK 101.120/2	33,3	8	50	M12	4	90	4xM8	25	4	0,6	1240	97	4,6	36310
LFK 101.120/2-k	33,3	8	50	M12	4	90	4xM8	25	4	0,6	1240	99	4,7	36320
LFK 101.140/2	38,3	10	50	M12	4	90	4xM10	50	7,5	0,6	1455	131	6,2	36330
LFK 101.140/2-k	38,3	10	50	M12	4	90	4xM10	50	4	0,6	1455	133	6,3	36340
LFK 134.120/2	38,3	10	40	M16	3	120	4xM10	50	5	0,5	2100	160	8,0	36400
LFK 134.140/2	38,3	10	55	M16	3	120	4xM10	50	5	0,5	2750	268	9,5	36410
LFK 134.140/2-k	38,3	10	55	M16	3	120	4xM10	50	5	0,5	2750	271	9,6	36420
LFK 134.160/2	43,3	12	60	M16	4	90	4xM12	87	8	0,5	3250	409	11,2	36430
LFK 134.160/2-k	43,3	12	60	M16	4	90	4xM12	87	5	0,5	3250	416	11,4	36440
LFK 155.140/2	33,3	8	50	M20	3	120	4xM12	87	6	0,4	4000	325	12,3	36500
LFK 155.160/2	43,3	12	60	M16	5	72	4xM12	87	6	0,4	4950	391	13,5	36510
LFK 155.180/2	48,8	14	70	M16	4	90	4xM12	147	6	0,4	5860	771	16,7	36520
LFK 155.180/2-k	48,8	14	70	M16	4	90	4xM12	147	6	0,4	5860	788	16,9	36530
LFK 155.200/2	53,8	14	80	M16	4	90	4xM12	147	10	0,4	6650	1131	19,5	36540
LFK 155.220/4	59,3	16	80	M20	4	90	4xM12	147	6	0,4	11000	1870	27,3	36550
LFK 155.250/4	64,4	18	100	M20	7	51,43	4xM12	147	6	0,4	15150	2918	32,2	36560
LFK 155.300/4	74,9	20	150	M20	7	51,43	4xM12	147	6	0,4	20250	5513	39,2	36570
LFK 155.300/4-k	74,9	20	150	M20	7	51,43	4xM12	147	6	0,4	20250	5541	39,4	36580
LFK 196.200/2	53,8	14	80	M20	5	72	4xM16	360	7	0,25	11380	1508	26,0	36600
LFK 196.250/2	64,4	18	100	M20	5	72	4xM20	695	13	0,25	14700	3353	37,0	36610
LFK 196.250/4	64,4	18	100	M20	5	72	4xM20	695	7	0,25	22400	3988	44,0	36620
LFK 196.310/4	85,4	22	150	M20	7	51,43	4xM20	695	7	0,25	33200	8302	56,0	36630
LFK 196.350/4	95,4	25	180	M20	7	51,43	4xM24	1220	7	0,25	42200	12586	65,0	36640
LFK 196.350/4-k	95,4	25	180	M20	7	51,43	4xM24	1220	7	0,25	42200	12780	66,0	36650
LFK 196.350/6	6)	6)	180	6)	6)	6)	6)	-	-	-	57300	15336	72,0	36660
LFK 280.400/4	6)	6)	200	6)	6)	6)	6)	-	10	0,2	50700	31500	126,0	36700
LFK 280.500/4	6)	6)	250	6)	6)	6)	6)	-	13	0,2	81060	74220	190,0	36710

-k= short series, dimension "X" is fixed

²⁾ for version A1

⁶⁾ to customer requirement

Selection table

Torque based life selection table

Order code	Life L_h [h]															
	1000				5000				10000				50000			
	Speed n [1/min]															
	50	150	500	1500	50	150	500	1500	50	150	500	1500	50	150	500	1500
	Torque T [Nm]															
LFK 44.50/2	60	43	30	22	37	27	19	13	30	22	15	11	25	18	12	9
LFK 44.70/2	97	70	48	35	60	43	30	21	48	35	24	17	39	28	20	14
LFK 44.70/2-k	97	70	48	35	60	43	30	21	48	35	24	17	39	28	20	14
LFK 44.70/4	128	92	64	46	79	57	39	28	64	46	32	23	52	37	26	19
LFK 74.70/2	221	159	111	80	136	98	68	49	111	80	55	40	90	65	45	32
LFK 74.90/2	322	232	161	116	199	143	100	72	161	116	81	58	131	94	66	47
LFK 74.90/2-k	322	232	161	116	199	143	100	72	161	116	81	58	131	94	66	47
LFK 74.120/2	451	324	226	163	278	200	140	100	226	163	113	81	184	132	92	66
LFK 74.120/2-k	451	324	226	163	278	200	140	100	226	163	113	81	184	132	92	66
LFK 74.120/4	679	488	340	245	419	301	210	151	340	245	171	123	276	199	139	100
LFK 74.150/4	1094	787	548	394	675	485	338	243	548	394	275	198	445	320	223	160
LFK 74.150/4-k	1094	787	548	394	675	485	338	243	548	394	275	198	445	320	223	160
LFK 101.100/2	629	453	315	227	388	279	195	140	315	227	158	114	256	184	128	92
LFK 101.120/2	825	594	414	297	509	366	255	184	414	297	207	149	336	242	168	121
LFK 101.120/2-k	825	594	414	297	509	366	255	184	414	297	207	149	336	242	168	121
LFK 101.140/2	1009	725	506	364	622	448	312	224	506	364	253	182	411	295	206	148
LFK 101.140/2-k	1009	725	506	364	622	448	312	224	506	364	253	182	411	295	206	148
LFK 134.120/2	1243	894	623	448	767	552	384	276	623	448	312	225	506	364	254	182
LFK 134.140/2	1582	1138	793	570	976	702	489	352	793	570	397	286	644	463	323	232
LFK 134.140/2-k	1582	1138	793	570	976	702	489	352	793	570	397	286	644	463	323	232
LFK 134.160/2	1847	1328	926	666	1140	820	571	411	926	666	464	334	752	541	377	271
LFK 134.160/2-k	1847	1328	926	666	1140	820	571	411	926	666	464	334	752	541	377	271
LFK 155.140/2	2302	1655	1153	830	1420	1021	712	512	1153	830	578	416	937	674	470	338
LFK 155.160/2	2895	2082	1451	1044	1786	1285	895	644	1451	1044	727	523	1178	848	591	425
LFK 155.180/2	3398	2444	1703	1225	2097	1508	1051	756	1703	1225	854	614	1383	995	693	499
LFK 155.180/2-k	3398	2444	1703	1225	2097	1508	1051	756	1703	1225	854	614	1383	995	693	499
LFK 155.200/2	3826	2752	1918	1379	2361	1698	1183	851	1918	1379	961	691	1558	1120	781	561
LFK 155.220/4	6323	4548	3169	2279	3901	2806	1955	1406	3169	2279	1588	1142	2574	1851	1290	928
LFK 155.250/4	8673	6237	4347	3126	5351	3849	2682	1929	4347	3126	2178	1567	3531	2539	1769	1273
LFK 155.300/4	11601	8344	5814	4182	7158	5149	3588	2580	5814	4182	2914	2096	4723	3397	2367	1702
LFK 155.300/4-k	11601	8344	5814	4182	7158	5149	3588	2580	5814	4182	2914	2096	4723	3397	2367	1702
LFK 196.200/2	6581	4733	3298	2372	4061	2921	2035	1464	3298	2372	1653	1189	2679	1927	1343	966
LFK 196.250/2	7660	5509	3839	2761	4726	3399	2369	1704	3839	2761	1924	1384	3118	2243	1563	1124
LFK 196.250/4	11725	8433	5876	4226	7235	5203	3626	2608	5876	4226	2945	2118	4773	3433	2392	1721
LFK 196.310/4	21228	15268	10639	7652	13098	9421	6565	4722	10639	7652	5332	3835	8642	6215	4331	3115
LFK 196.350/4	21931	15773	10991	7905	13532	9732	6782	4878	10991	7905	5509	3962	8928	6421	4474	3218
LFK 196.350/4-k	21931	15773	10991	7905	13532	9732	6782	4878	10991	7905	5509	3962	8928	6421	4474	3218
LFK 196.350/6	30845	22184	15860	11195	18430	13595	9063	6677	15353	10639	7320	5437	11937	8579	6124	4405
LFK 280.400/4	31166	22415	16025	11312	19230	13736	9157	6747	15513	10639	7396	5494	12601	8669	6188	4451
LFK 280.500/4	45947	33045	23625	16676	28350	20250	13500	9947	22869	16039	11807	8102	18577	12781	9123	6562

-k= short series

Selection table

Power based life selection table

Order code	Life L_h [h]															
	1000				5000				10000				50000			
	Speed n [1/min]															
	50	150	500	1500	50	150	500	1500	50	150	500	1500	50	150	500	1500
	Power P_B [kW]															
LFK 44.50/2	0,3	0,7	1,6	3,4	0,2	0,4	1,0	2,1	0,2	0,3	0,8	1,7	0,1	0,3	0,6	1,4
LFK 44.70/2	0,5	1,1	2,5	5,5	0,3	0,7	1,6	3,4	0,3	0,5	1,3	2,7	0,2	0,4	1,0	2,2
LFK 44.70/2-k	0,5	1,1	2,5	5,5	0,3	0,7	1,6	3,4	0,3	0,5	1,3	2,7	0,2	0,4	1,0	2,2
LFK 44.70/4	0,7	1,4	3,3	7,2	0,4	0,9	2,1	4,5	0,3	0,7	1,7	3,6	0,3	0,6	1,4	2,9
LFK 74.70/2	1,2	2,5	5,8	12,5	0,7	1,5	3,6	7,7	0,6	1,3	2,9	6,3	0,5	1,0	2,4	5,1
LFK 74.90/2	1,7	3,6	8,5	18,2	1,0	2,2	5,2	11,3	0,8	1,8	4,2	9,1	0,7	1,5	3,4	7,4
LFK 74.90/2-k	1,7	3,6	8,5	18,2	1,0	2,2	5,2	11,3	0,8	1,8	4,2	9,1	0,7	1,5	3,4	7,4
LFK 74.120/2	2,4	5,1	11,8	25,5	1,5	3,1	7,3	15,8	1,2	2,6	5,9	12,8	1,0	2,1	4,8	10,4
LFK 74.120/2-k	2,4	5,1	11,8	25,5	1,5	3,1	7,3	15,8	1,2	2,6	5,9	12,8	1,0	2,1	4,8	10,4
LFK 74.120/4	3,6	7,7	17,8	38,5	2,2	4,7	11,0	23,7	1,8	3,8	8,9	19,3	1,4	3,1	7,3	15,7
LFK 74.150/4	5,7	12,4	28,7	61,9	3,5	7,6	17,7	38,2	2,9	6,2	14,4	31,0	2,3	5,0	11,7	25,2
LFK 74.150/4-k	5,7	12,4	28,7	61,9	3,5	7,6	17,7	38,2	2,9	6,2	14,4	31,0	2,3	5,0	11,7	25,2
LFK 101.100/2	3,3	7,1	16,5	35,6	2,0	4,4	10,2	22,0	1,7	3,6	8,3	17,9	1,3	2,9	6,7	14,5
LFK 101.120/2	4,3	9,3	21,7	46,7	2,7	5,8	13,4	28,8	2,2	4,7	10,9	23,4	1,8	3,8	8,8	19,0
LFK 101.120/2-k	4,3	9,3	21,7	46,7	2,7	5,8	13,4	28,8	2,2	4,7	10,9	23,4	1,8	3,8	8,8	19,0
LFK 101.140/2	5,3	11,4	26,5	57,1	3,3	7,0	16,3	35,2	2,6	5,7	13,3	28,6	2,2	4,6	10,8	23,3
LFK 101.140/2-k	5,3	11,4	26,5	57,1	3,3	7,0	16,3	35,2	2,6	5,7	13,3	28,6	2,2	4,6	10,8	23,3
LFK 134.120/2	6,5	14,0	32,6	70,4	4,0	8,7	20,1	43,4	3,3	7,0	16,3	35,3	2,6	5,7	13,3	28,6
LFK 134.140/2	8,3	17,9	41,5	89,6	5,1	11,0	25,6	55,3	4,2	9,0	20,8	44,9	3,4	7,3	16,9	36,5
LFK 134.140/2-k	8,3	17,9	41,5	89,6	5,1	11,0	25,6	55,3	4,2	9,0	20,8	44,9	3,4	7,3	16,9	36,5
LFK 134.160/2	9,7	20,9	48,5	104,6	6,0	12,9	29,9	64,5	4,8	10,5	24,3	52,4	3,9	8,5	19,7	42,6
LFK 134.160/2-k	9,7	20,9	48,5	104,6	6,0	12,9	29,9	64,5	4,8	10,5	24,3	52,4	3,9	8,5	19,7	42,6
LFK 155.140/2	12,1	26,0	60,4	130,3	7,4	16,0	37,3	80,4	6,0	13,0	30,3	65,3	4,9	10,6	24,6	53,1
LFK 155.160/2	15,2	32,7	76,0	163,9	9,4	20,2	46,9	101,1	7,6	16,4	38,1	82,2	6,2	13,3	30,9	66,7
LFK 155.180/2	17,8	38,4	89,2	192,4	11,0	23,7	55,0	118,7	8,9	19,2	44,7	96,4	7,2	15,6	36,3	78,3
LFK 155.180/2-k	17,8	38,4	89,2	192,4	11,0	23,7	55,0	118,7	8,9	19,2	44,7	96,4	7,2	15,6	36,3	78,3
LFK 155.200/2	20,0	43,2	100,4	216,6	12,4	26,7	62,0	133,7	10,0	21,7	50,3	108,6	8,2	17,6	40,9	88,2
LFK 155.220/4	33,1	71,4	165,9	358,0	20,4	44,1	102,4	220,9	16,6	35,8	83,2	179,4	13,5	29,1	67,5	145,7
LFK 155.250/4	45,4	98,0	227,6	491,1	28,0	60,5	140,4	303,0	22,8	49,1	114,1	246,1	18,5	39,9	92,6	199,9
LFK 155.300/4	60,7	131,1	304,4	656,9	37,5	80,9	187,9	405,3	30,4	65,7	152,6	329,2	24,7	53,4	123,9	267,4
LFK 155.300/4-k	60,7	131,1	304,4	656,9	37,5	80,9	187,9	405,3	30,4	65,7	152,6	329,2	24,7	53,4	123,9	267,4
LFK 196.200/2	34,5	74,3	172,7	372,6	21,3	45,9	106,6	229,9	17,3	37,3	86,6	186,8	14,0	30,3	70,3	151,7
LFK 196.250/2	40,1	86,5	201,0	433,7	24,7	53,4	124,0	267,6	20,1	43,4	100,7	217,4	16,3	35,2	81,8	176,6
LFK 196.250/4	61,4	132,5	307,7	663,9	37,9	81,7	189,9	409,6	30,8	66,4	154,2	332,7	25,0	53,9	125,3	270,3
LFK 196.310/4	111,1	239,8	557,1	1202,0	68,6	148,0	343,7	741,7	55,7	120,2	279,2	602,4	45,2	97,6	226,8	489,3
LFK 196.350/4	114,8	247,8	575,5	1241,7	70,9	152,9	355,1	766,2	57,6	124,2	288,4	622,3	46,7	100,9	234,3	505,5
LFK 196.350/4-k	114,8	247,8	575,5	1241,7	70,9	152,9	355,1	766,2	57,6	124,2	288,4	622,3	46,7	100,9	234,3	505,5
LFK 196.350/6	161,5	348,4	830,4	1758,4	96,5	213,5	474,5	1048,4	80,4	229,9	383,2	854,0	62,5	134,7	320,6	691,1
LFK 280.400/4	163,2	351,1	839,4	1776,8	100,7	215,7	479,4	1059,7	81,2	232,3	387,2	862,9	65,9	136,2	324,0	699,1
LFK 280.500/4	240,6	519,2	1237,8	2619,3	148,4	318,1	706,8	1362,3	119,0	342,2	570,1	1272,6	97,3	200,7	477,6	1030,7

-k= short series

Dimensions for GFL

GFL - separable flanges

For versions A4 and A6.

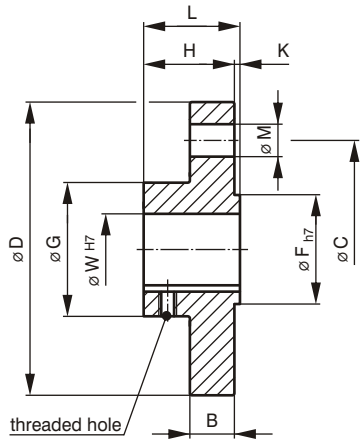

A4

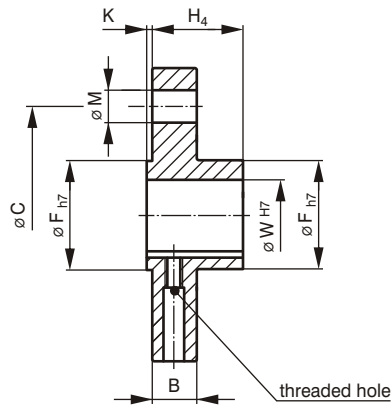

A6

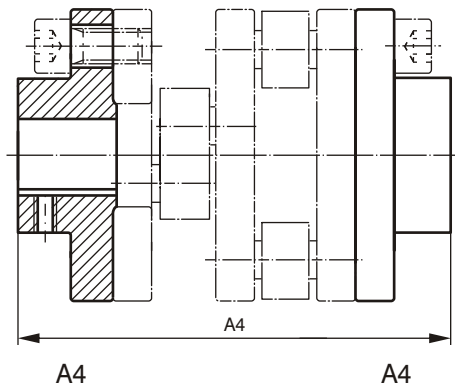
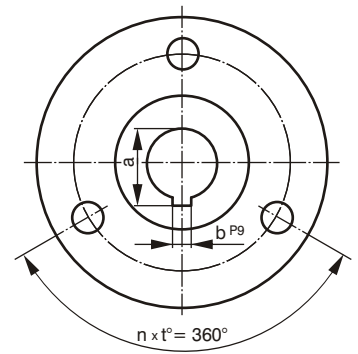

A4

A4

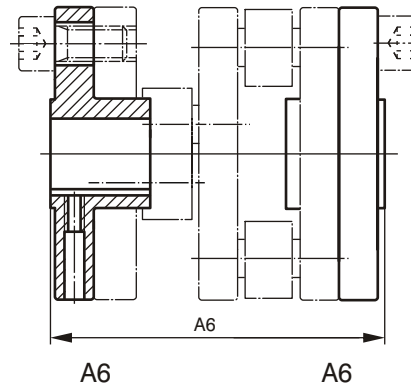

A6

A6

Ordering example:

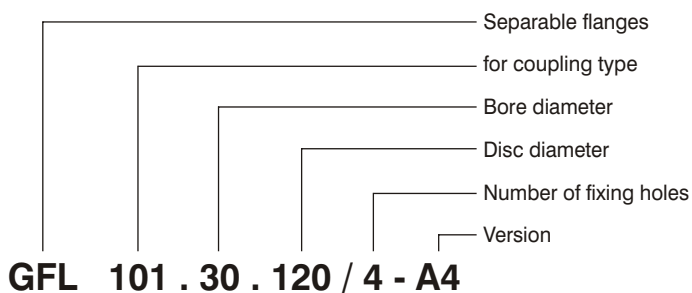

Order code	Dimensions [mm]														Mounting holes			Mass moment of inertia J [kg cm ²]	Mass [kg]	CAD-Nr.:
	B	C	D	F	G	H	H ₄	K	L	W ¹⁾	W _{max.}		a ²⁾	b ²⁾	Bore M	Number n	Hole pitch t [°]			
											A4	A6								
GFL 44.14.50/3	8	35	50	22	24	20	16	2	22	14	14	14	16,3	5	6,6	3	120	0,4	0,14	37001
GFL 44.16.70/4	8	56	70	25	35	20	16	2	22	16	22	16	18,3	5	6,6	4	90	1,5	0,29	37002
GFL 74.16.70/3	10,5	48	70	25	31	20	20	2	22	16	18	16	18,3	5	11	3	120	2,0	0,32	37101
GFL 74.25.90/3	10,5	70	90	45	53	37	21	3	40	25	40	33	28,3	8	11	3	120	6,4	0,85	37102
GFL 74.30.120/3	10,5	98	120	50	60	42	40	3	45	30	45	38	33,3	8	11	3	120	18,0	1,40	37103
GFL 74.35.150/4	10,5	128	150	60	70	42	40	3	45	35	50	45	38,3	10	14	4	90	41,7	2,04	37104
GFL 101.30.100/3	15,5	70	100	40	45	37	31	3	40	30	30	30	33,3	8	18	3	120	11,5	0,95	37301
GFL 101.30.120/4	15,5	90	120	50	65	42	42	3	45	30	45	38	33,3	8	14	4	90	27,0	1,8	37302
GFL 101.35.140/4	15,5	110	140	50	70	52	52	3	55	35	45	38	38,3	10	14	4	90	48,3	2,5	37303
GFL 134.30.120/3	22,5	90	120	40	65	52	45	3	55	30	35	30	33,3	8	18	3	120	39,2	2,4	37501
GFL 134.35.140/3	22,5	100	140	55	70	52	45	3	55	35	50	40	38,3	10	18	3	120	69,8	3,1	37502
GFL 134.40.160/4	22,5	120	158	60	85	52	52	3	55	40	55	45	43,3	12	18	4	90	114,5	4,2	37503
GFL 155.30.140/3	25	100	140	40	69	46	50	3	49	30	30	30	33,3	8	22	3	120	77,2	3,2	37701
GFL 155.40.160/5	25	115	160	60	75	52	50	3	55	40	55	45	43,3	12	18	5	72	128,2	4,0	37702
GFL 155.45.180/4	25	135	180	70	90	62	62	3	65	45	60	53	48,8	14	18	4	90	210,7	5,95	37703
GFL 155.50.200/4	25	152	200	80	100	72	72	3	75	50	70	65	53,8	14	18	4	90	324,7	7,8	37704
GFL 155.55.220/4	25	180	220	80	120	80	50	3	83	55	70	65	59,3	16	22	4	90	503,7	10,6	37705
GFL 155.60.250/7	25	210	250	100	120	80	80	3	83	60	80	80	64,4	18	22	7	51,43	779	12,4	37706
GFL 155.70.300/7	25	260	300	150	140	95	80	3	98	70	80	80	74,9	20	22	7	51,43	1619	17,6	37707
GFL 196.50.200/5	30	150	200	80	100	70	70	5	75	50	70	65	53,8	14	22	5	72	386	8,5	37801
GFL 196.60.250/5	30	200	250	100	120	80	80	5	85	60	80	80	64,4	18	22	5	72	932	14,0	37802
GFL 196.80.310/7	30	260	310	150	160	95	95	5	100	80	100	100	85,4	22	22	7	51,43	2230	24,2	37803
GFL 196.90.350/7	30	280	350	180	200	135	100	5	140	90	110	110	95,4	25	22	7	51,43	4304	42,1	37804

¹⁾ Dimension "W" for the bore is a preferred value.

²⁾ Values for dimension "W" with key to BS 4235 (DIN 6885/1).

Dimensions for ISP-D

ISP-D - Inkofix tension flange

For version A3.

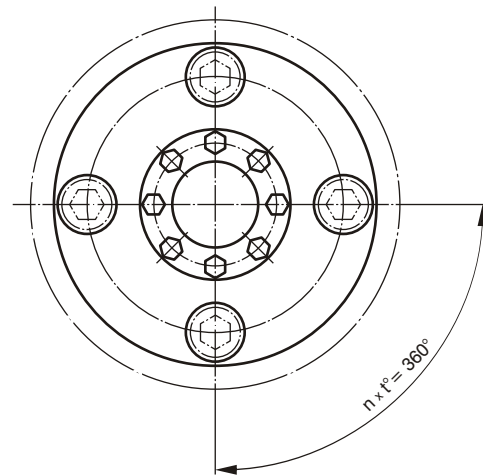
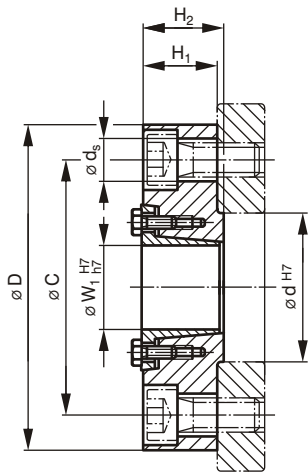

Explanation:

- T_{stat} = maximum transmissible torque for tension flange
- F_{ax} = maximum transmissible axial force for tension flange
- T_A = required tightening torque of the tension screws

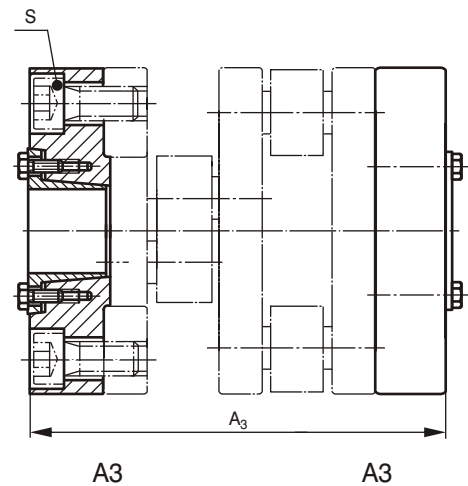

Ordering example:

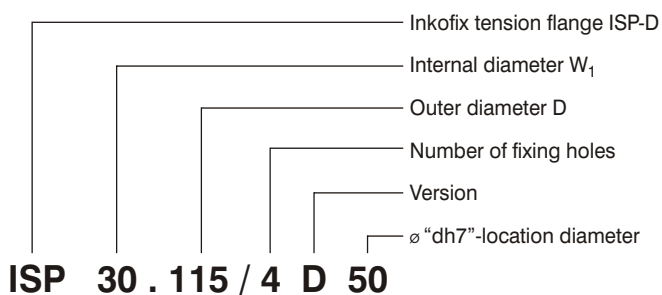

Lineflex couplings

Order code Coupling	Order code Tension flange	Dimensions [mm]						Mounting holes								
		d	C	D	H ₁	H ₂	W ₁ ¹⁾	Bore d _s [mm]	Number n	Hole pitch t [°]						
LFK 74.90/2	ISP 25.90/3D45	45	70	90	14	17	25	11	3	120						
LFK 74.120/2; /4	ISP 30.120/3D50	50	98	120	24	27	30	11	3	120						
LFK 74.150/4	ISP 35.150/4D60	60	128	150	24	27	35	13	4	90						
LFK 101.120/2	ISP 30.115/4D50	50	90	115	25	28	30	13	4	90						
LFK 101.140/2	ISP 35.135/4D50	50	110	135	30	33	35	13	4	90						
LFK 134.140/2	ISP 35.130/3D55	55	100	130	35	38	35	18	3	120						
LFK 134.160/2	ISP 40.150/4D60	60	120	150	35	38	40	18	4	90						
LFK 155.160/2	ISP 40.145/5D60	60	115	145	45	48	40	18	5	72						
LFK 155.180/2	ISP 45.165/4D70	70	135	165	45	48	45	18	4	90						
LFK 155.200/2	ISP 50.185/4D80	80	152	185	55	58	50	18	4	90						
LFK 155.220/4	ISP 55.220/4D80	80	180	220	55	58	55	22	4	90						
LFK 155.250/4	ISP 60.250/7D100	100	210	250	65	70	60	22	7	51,43						
LFK 155.300/4	ISP 70.300/7D150	150	260	300	65	70	70	22	7	51,43						
LFK 196.200/2	ISP 50.190/5D80	80	150	190	65	70	50	22	5	72						
LFK 196.250/2; /4	ISP 60.240/5D100	100	200	240	70	75	60	22	5	72						

¹⁾ Dimension "W₁" for the bore is a preferred value.

Order code Coupling	Order code Tension flange	Tension screw		Operational data			Mounting screws ²⁾	Mass [kg]	CAD-Nr.:				
		ISO 4017 (DIN 933) 10.9	Tightening torque T _A [Nm]	Torque T _{stat.} [Nm]	max. axial force F _{ax} [kN]	Mass moment of inertia J [kg cm ²]							
LFK 74.90/2	ISP 25.90/3D45	8xM5x16	12	595	48	6,5	3xM10x16	0,6	53903				
LFK 74.120/2; /4	ISP 30.120/3D50	8xM6x16	16,5	1224	82	36	3xM10x20	1,9	53904				
LFK 74.150/4	ISP 35.150/4D60	8xM6x16	16,5	1690	97	95	4xM12x20	3,2	53905				
LFK 101.120/2	ISP 30.115/4D50	8xM6x16	16,5	1440	96	34	4xM12x25	1,9	53906				
LFK 101.140/2	ISP 35.135/4D50	8xM6x16	16,5	1690	97	75	4xM12x30	3,1	53907				
LFK 134.140/2	ISP 35.130/3D55	8xM8x25	40	2980	170	77	3xM16x35	3,4	53908				
LFK 134.160/2	ISP 40.150/4D60	8xM8x25	40	3400	170	135	4xM16x35	4,5	53909				
LFK 155.160/2	ISP 40.145/5D60	6xM10x30	79	5460	273	153	5xM16x50	5,4	53910				
LFK 155.180/2	ISP 45.165/4D70	8xM10x30	79	6320	281	256	4xM16x50	7,0	53911				
LFK 155.200/2	ISP 50.185/4D80	8xM10x30	79	7180	287	496	4xM16x60	10,8	53912				
LFK 155.220/4	ISP 55.220/4D80	8xM12x40	135	11920	433	996	4xM20x55	15,5	53913				
LFK 155.250/4	ISP 60.250/7D100	8xM12x40	135	16070	536	1966	7xM20x65	23,8	53914				
LFK 155.300/4	ISP 70.300/7D150	8xM14x50	215	21930	627	4116	7xM20x65	34,7	53915				
LFK 196.200/2	ISP 50.190/5D80	8xM12x40	135	12400	496	656	5xM20x70	13,6	53916				
LFK 196.250/2; /4	ISP 60.240/5D100	8xM12x40	135	15860	529	1798	5xM20x75	23,5	53917				

²⁾ Mounting screws are not supplied.

³⁾ DIN 6912/ 7984