

INKOMA - GROUP

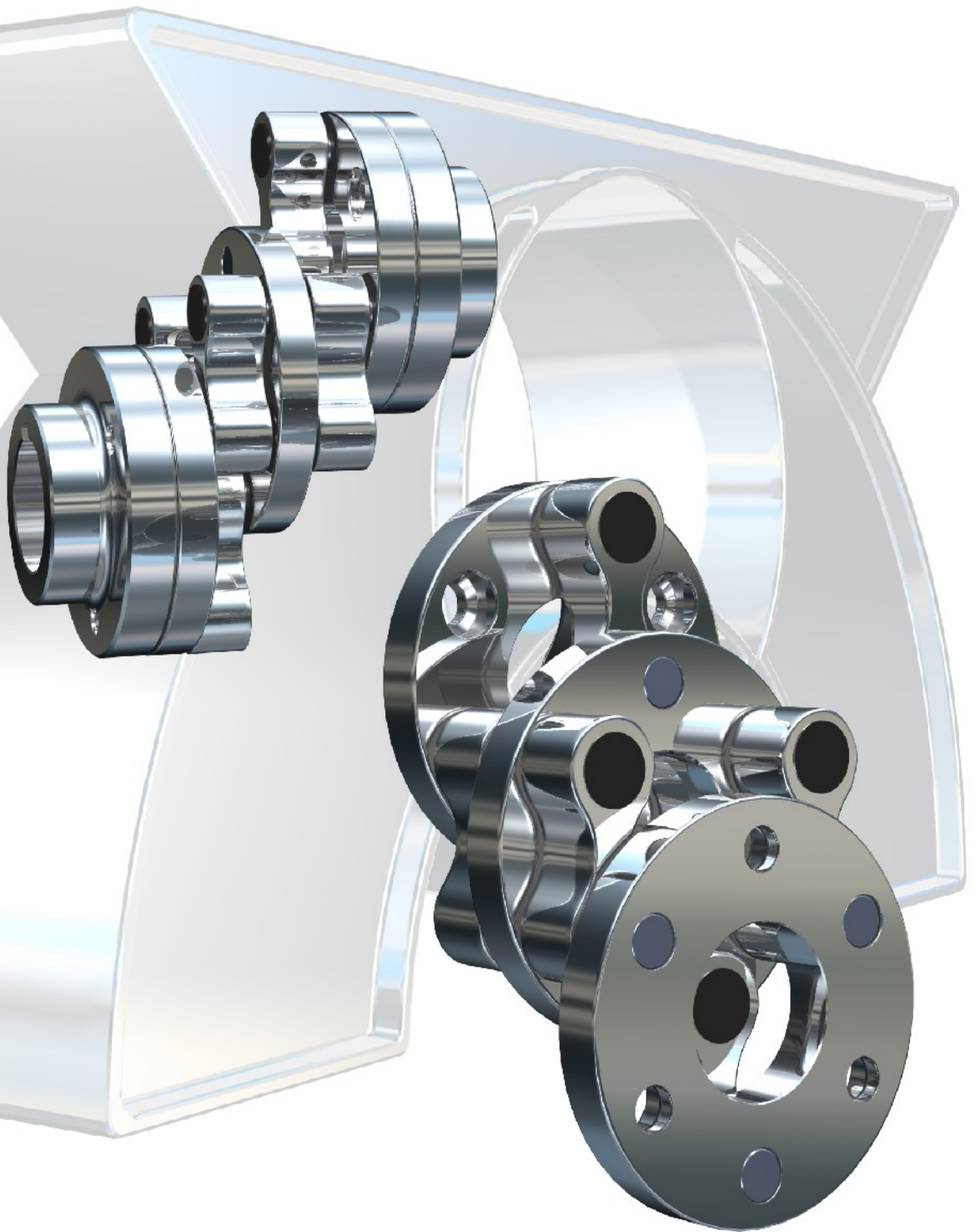

The INKOMA-PK coupling is a device for the transmission of torque between axially parallel but displaced shafts. The radial offset can be adjusted statically or dynamically, within its operating limits.

The coupling principle is based on parallel linkages. Each movement at the input is faithfully replicated at the output. There is no relative motion due to displacements as there is with universal joints.

Features of the INKOMA-PK coupling:

- input and output completely synchronous, regardless of the offset
- damps and compensates for radial oscillations
- pure torque transmission so that no reactive force is transmitted to related shaft bearings
- small space requirement compared to degree of offset
- within the specified limits any degree of offset can be tolerated either statically or dynamically

The INKOMA-PK coupling is available in the following versions:

A1 = Basic version:

Both outer discs have fixing holes for connecting components.

A2 = Hub version:

Both outer discs have finished bores in outward facing hubs and keyways to BS 4235 (DIN 6885).

A3 = Tension hub version:

Basic version A1 with additional shrink disc. The shrink disc allows keyless fitting to the shaft.

A4 = Separable hub version:

Basic version A1 with additional adaptor flanges. These flanges have hubs for shaft fitting.

A7 = Split hub version:

This hub version has two components - a fixed and a removable part allowing radial clamping to the shaft. This version requires no axial displacement of the shaft for assembly and disassembly.

Combinations:

Each coupling can combine any of these versions. E.g. A1/A2 - one disc with fixing holes and the other with outward facing bored hub.

Special versions:

In addition to basic versions, customer specific executions are also possible e.g. incorporating sprocket, gears, shaft, etc. in the outer discs.

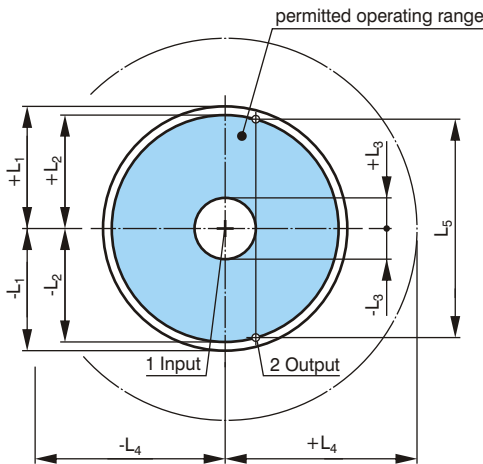

- L₁ limit of displacement
- L₂ permitted operating range
- L₃ minimum offset
- L₄ max. displacement of centre flange
- L₅ max. tangential working offset

Order code	limit of displacement	permitted operating range	Minimum offset	max. displacement of centre flange	max. tangential working offset	Torque	Mass moment of inertia ²⁾
	L ₁ [mm]	L ₂ [mm]	L ₃ [mm]	L ₄ [mm]	L ₅ [mm]	T _{stat.} [Nm]	J [kg cm ²]
NA 44.25.50/3 ¹⁾	25	23,5	5,5	38	45	34	1,2
NA 44.25.50/4 ¹⁾	25	23,5	5,5	38	45	45	1,5
NA 44.25.70/6 ¹⁾	25	23,5	5,5	58	45	110	2,7
NA 74.36.70/3	36	34	9	53	65	105	4,9
NA 74.36.90/3	36	34	9	63	65	153	15
NA 74.70.90/3	70	67	17,5	80	126	153	16
NA 74.36.90/4	36	34	9	63	65	203	16
NA 74.36.90/5	36	34	9	63	65	255	16
NA 74.120.120/3	120	114	30	120	216	213	53
NA 74.36.120/4	36	34	9	78	65	285	52
NA 74.70.120/4	70	67	17,5	95	126	285	52
NA 74.36.150/4	36	34	9	93	65	372	118
NA 74.70.150/4	70	67	17,5	110	126	372	121
NA 74.120.150/4	120	114	30	135	216	372	127
NA 101.56.100/3	56	53	14	68	100	425	43
NA 101.56.120/3	56	53	14	88	100	540	72
NA 101.90.120/3	90	86	22	105	162	540	73
NA 101.56.120/4	56	53	14	88	100	729	81
NA 101.120.140/3	120	114	30	130	216	660	154
NA 101.56.140/4	56	53	14	98	100	880	157
NA 101.90.140/4	90	86	22	115	162	880	158
NA 101.160.160/3	160	152	40	160	288	780	246
NA 101.56.160/4	56	53	14	108	100	1040	250
NA 101.90.160/4	90	86	22	125	162	1040	250
NA 101.120.160/4	120	114	30	140	216	1040	250
NA 134.64.140/3	64	61	16	102	115	1178	213
NA 134.90.140/3	90	86	22	115	162	1178	225
NA 134.64.160/3	64	61	16	112	115	1413	278
NA 134.90.160/3	90	86	22	125	162	1413	294
NA 134.120.160/3	120	114	30	140	216	1413	310
NA 134.64.160/4	64	61	16	112	115	1884	310
NA 134.90.160/4	90	86	22	125	162	1884	330
NA 155.72.160/3	72	68	18	116	130	2130	410
NA 155.72.160/4	72	68	18	116	130	2780	438
NA 155.100.160/3	100	95	25	130	180	2130	429
NA 155.72.180/3	72	68	18	126	130	2500	628
NA 155.100.180/3	100	95	25	140	180	2500	631
NA 155.72.180/4	72	68	18	126	130	3335	689
NA 155.160.200/3	160	152	40	180	288	2815	880
NA 155.72.200/4	72	68	18	136	130	3755	870
NA 155.100.200/4	100	95	25	150	180	3755	895
NA 196.90.200/3	90	86	22,5	145	162	8800	1195
NA 196.150.200/3	150	145	37,5	175	270	8800	1280
NA 196.90.200/4	90	86	22,5	145	162	11800	1435
NA 196.90.250/4	90	86	22,5	170	162	15800	2695
NA 196.150.250/4	150	145	37,5	200	270	15800	2875
NA 196.90.250/5	90	86	22,5	170	162	19000	2906
NA 196.90.250/6	90	86	22,5	170	162	23000	3125
NA 196.90.310/6	90	86	22,5	200	162	30000	6667
NA 196.150.310/6	150	145	37,5	230	270	30000	7087
NA 280.150.350/4	150	145	37	250	270	31000	20000
NA 280.150.350/5	150	145	37	250	270	39000	21200
NA 280.150.400/5	150	145	37	275	270	46000	34000
NA 280.150.400/6	150	145	37	275	270	55000	34500
NA 280.150.500/6	150	145	37	325	270	73000	80100

¹⁾ not fixed axially

²⁾ for version A1

Additional versions for light or heavy duty are to be found in the brochure.



FRANCIS AND FRANCIS Ltd.
 PO Box 3284
 South Croydon / CR2 1FU
 Phone: +44 (0)20 8668 9792
 Fax: +44 (0)20 8668 9793
 E-Mail: Sales@powertransmissions.co.uk
 Internet: www.powertransmissions.co.uk

INKOMA-GROUP



Request our [complete catalogue](#) or visit us on the [Internet](#). You can obtain a free download of our brochure or the product drawing of the selected item using the [CADENAS](#) facility.